



SAFETY STANDARDS OF ORLEN S.A.

***Occupational Health and Safety executive
guidelines for Contractors***

Coordination:

Team

Group OHS and Prevention
Coordination Department

Acceptance:

Head of the

Group OHS and Prevention
Coordination Department

Approval:

Head of the

Occupational
Health and Safety Office

Płock, January 2024

	<p style="text-align: center;">SAFETY STANDARDS</p>	<p style="text-align: center;">ORLEN S.A.</p>
<p>Version: January 2024</p>	<p style="text-align: center;">OCCUPATIONAL HEALTH AND SAFETY EXECUTIVE GUIDELINES FOR CONTRACTORS</p>	<p style="text-align: center;">Page no.: 1</p>

INTRODUCTION

These safety guidelines contain a set of basic requirements resulting from experience and knowledge of ORLEN's employees, as well as internal ordinances, including the Comprehensive Prevention System (KSP), and current external regulations. If the name *PKN ORLEN S.A.* is used in internal documents, it should be understood as the new name *ORLEN S.A.*

The document covers technical conditions in the field of work safety, process safety and fire protection, which should be met by constructed, reconstructed, renovated objects or installations in these areas, and should be included in the execution process at ORLEN SA.

The "Guidelines" contains a set of requirements resulting The use of the information contained therein will facilitate the execution and collection of completed investments and projects, and will ensure an appropriate level of safety for the facilities put into operation.

In the event of circumstances preventing the construction of facilities in accordance with these provisions, it is allowed to deviate from them after prior agreement with the competent persons managing the Departments in the Occupational Health and Safety Office.

In connection with the above, ORLEN SA nor any person involved in the development of these Guidelines, can not be held legally liable for the use of the information contained in this document, nor for any damage/ accidents that arise as a result of improper application of the requirements or information contained therein. They will be used to supplement or/ and improve this study. Reproduction and copying without the consent of the owners (authors) is prohibited. The prohibition does not apply to the citation of publications with reference to the source.



 ORLEN	SAFETY STANDARDS	ORLEN S.A.
Version: January 2024	OCCUPATIONAL HEALTH AND SAFETY EXECUTIVE GUIDELINES FOR CONTRACTORS	Page no.: 2

Item	Regulation from the Comprehensive Prevention System regarding	Page no.
1.	Comprehensive Prevention System, the "Orlen SAFETY FIRSTS for Contractors " and the "Safety's Firsts for the ORLEN Petrol Stations".	4
2.	Plan of division and allocation of areas of ORLEN SA in Płock.	5
3.	Management of protective clothing, protective footwear, personal protection equipment, as well as the provision of personal hygiene equipment and means for providing first aid for individual work positions in ORLEN S.A.	7
4.	Safe use of mobile communication devices, including mobile phones and other portable multimedia devices. in the production and logistics facilities of ORLEN S.A.	13
5.	The procedure for establishing the circumstances and causes of accidents at work, accidents on the way to work or from work, occupational diseases, work safety hazards and potentially accidental events as well as the procedures for ensuring proper care for victims of accident events at work at ORLEN S.A.	14
6.	The Work Safety Day in the ORLEN S.A.	15
7.	Principles, scope and implementation of training in the field of occupational health and safety and other obligatory training at ORLEN S.A. and the method of their documentation.	15
8.	Application of the Process Safety Management System at the ORLEN S.A.	19
9.	The implementation of works based on written permits at the Production Facility in Płock, PTA Facility in Włocławek, CCTG Facility in Włocławek and the Fuel Terminals located outside Płock.	20
10.	Work at heights at ORLEN S.A.	23
11.	Conducting earthworks at ORLEN S.A.	26
12.	Works inside tanks, closed apparatus and in drains at ORLEN S.A.	28
13.	Detailed rules for determining qualifications of persons dealing with the exploitation of equipment, installations and electrical networks at the ORLEN S.A.	34
14.	The protection of nitrogen and air pipelines against their contamination with dangerous media at the Production Facility in Płock.	35
15.	Recording of setting up and removal of plugs at the premises of ORLEN S.A.	38
16.	Introduction to the "Instructions for the control and operation of PiA interlock systems supervised by the Technology Office".	38
17.	Introduction to the "Rules of conduct in the field of telecommunication infrastructure on the premises of the Production Facility in Płock and the PTA Facility in Włocławek".	39
18.	Introduction to the official use of the Instruction of organization of safe work on electrical power equipment, installations and power grids in ORLEN S.A.	40
19.	Monitoring the technical condition of equipment in the ORLEN S.A.	44

	SAFETY STANDARDS	ORLEN S.A.
Version: January 2024	OCCUPATIONAL HEALTH AND SAFETY EXECUTIVE GUIDELINES FOR CONTRACTORS	Page no.: 3

20.	The occupational health and safety requirements for employees at workplaces where explosive atmospheres may occur at the ORLEN S.A.	54
21.	The classification of areas with potentially explosive atmospheres in ORLEN S.A. and the ORLEN Capital Group.	58
22.	Implementation of the Instruction for the carriage of dangerous goods by land transport on the premises of ORLEN S.A. and for the benefit of ORLEN S.A.	58
23.	Procedures for location of temporary facilities and organization of construction sites for Contractors on the premises of the Production Facility in Płock, the PTA Facility in Włocławek, CCGT Włocławek or adjacent areas.	63
24.	Introduction for official use of the "Instructions for radiological protection at the premises of ORLEN S.A."	70
Fuel terminals		
25.	The safety of loading and unloading of road tankers at the Fuel Terminals of ORLEN S.A.	71
Fire Protection		
26.	Fire and Chemical Safety Regulations of ORLEN S.A.	72
27.	Security posts at the Production Facility in Płock and the PTA Facility in Włocławek.	77
28.	The use of fire water network and marking and maintenance of hydrants at the Production Facility in Płock.	77
Additional guidelines applicable on the premises of ORLEN		
29.	Additional guidelines clarifying the rules of ordering, commissioning and carrying out works using mobile cranes and lifts, ie lifting devices mounted on vehicles, on the premises of the Production Facility in Płock, PTA and CCGT Facility in Włocławek and the Fuel Terminals.	78
30.	Safe work conditions on the installations renovation site.	80
31.	Additional guidelines regarding the EXCAVATION CONTROL CARD, places and methods of marking excavations during works carried out at the Production Facility in Płock.	82
32.	Additional guidelines for the supervision of the construction and operation of scaffolding during works at the Production Facility in Płock, CCGT Włocławek and PTA Facility in Włocławek.	82
33.	Additional guidelines regarding use of electrical equipment: construction switchboards, extension cords, power generation sets and others.	85
34.	Guidelines for the management of assembly auxiliary lifting equipment.	92
35.	Additional guidelines regarding the use of detectors.	96



	SAFETY STANDARDS	ORLEN S.A.
Version: January 2024	OCCUPATIONAL HEALTH AND SAFETY EXECUTIVE GUIDELINES FOR CONTRACTORS	Page no.: 4

1. Regulation regarding Comprehensive Prevention System, the "Orlen SAFETY FIRSTS for Contractors" and the "Safety's Firsts for the ORLEN Petrol Stations".

Comprehensive Prevention System is the basic element of the Occupational Safety and Health Management System. It includes a set of internal organizational acts in the field of occupational health and safety, fire and chemical safety, radiological protection, technical safety and process safety.

The Comprehensive Prevention System and the "Orlen SAFETY FIRSTS for Contractors" are applicable for:

- employees of all external contractors performing tasks at the premises of ORLEN SA,
- all persons staying on the premises of ORLEN SA, in their scope, in accordance with separate internal organizational acts and provisions of generally applicable law.

Failure to comply or serious violation of the arrangements and procedures in KSP, the "Orlen SAFETY FIRSTS for Contractors" or "SAFETY'S FIRSTS for the ORLEN Petrol Stations" is treated as a violation of basic duties by the employee.

Annex no. 1 to the General Safety Requirements – ORLEN SAFETY FIRSTS for the Contractors



10

ORLEN SAFETY FIRSTS



1

I ALWAYS USE PERSONAL PROTECTIVE EQUIPMENT ADAPTED TO THE HAZARDS AND SUITABLE FOR THEIR INTENDED USE
I use all personal protective equipment in accordance with their intended purpose, adapted to the hazards present at the workplace. I only use efficient equipment and replace used ones.

2

I ALWAYS WORK IN ACCORDANCE WITH A PERMIT OR WRITTEN INSTRUCTIONS
I never start work without complying with the safety conditions specified in the permit or written instructions. From the beginning to the end of work, I always apply the health and safety rules specified in the permit or instruction.

3

BEFORE STARTING WORK, I CHECK WHETHER THE LOTO LOCKS ARE USED AND WHETHER THE HAZARDOUS ENERGY HAS BEEN RESET
When preparing the workplace, I always use the LOTO Manual. Acting as a Belayer, I always check if the locks and their tags are installed correctly.

4

ACTING AS A BELAYER, I ALWAYS REACT TO DANGEROUS BEHAVIORS
I always watch over the safe execution of work and compliance with the conditions of the permit. I stop work immediately when I see a flagrant breach of safety rules.

5

I ALWAYS USE A PERSONAL DETECTOR AND DO NOT IGNORE THE SIGNALS IT SENDS
I never enter the Installation area without a personal detector that is operational and switched on. If the detector signals a threat, I immediately stop working, leave the danger zone and raise the alarm.

6

I DO NOT IGNORE ALARMS AND WARNING SIGNALS OF DEVICES AND SYSTEMS MONITORING SAFE PROCESS CONDUCT
I always watch over the safe conduct of the process, I do not use private mobile phones in the control room. I always respond to alarms and warning signals.

7

WHEN WORKING WITH CHEMICAL SUBSTANCES, I ALWAYS USE REQUIRED PERSONAL PROTECTIVE EQUIPMENT AND CARE ABOUT THE LABELING AND STORAGE OF THE SUBSTANCE
When working with chemical substances, I always follow the provisions of the safety data sheet. I always pay attention to the proper labeling and storage of substances.

8

IN CASE OF A CHEMICAL ALARM, I ALWAYS TAKE THE ESCAPE HOOD AND HEAD TO THE MEETING POINT FOR EVACUATION, PERPENDICULAR TO THE WIND
I never ignore the sound of an alarm. I always follow the instructions of the person in charge of the rescue operations.

9

I ALWAYS PROVIDE FIRST AID
I always provide or organize first aid for the injured person. I always assess the place of the incident in terms of possible threats, I care about my own safety.

10

SEEING AN ACCIDENT, FIRE OR A BREAKDOWN, I ALWAYS CALL COMPANY EMERGENCY NUMBER – 19 998
I always call the emergency services using the Company Emergency Number 19 998. If my life and health are in danger, I always stop work and inform my supervisor.

TOGETHER WE BUILD SAFE ORLEN.



	SAFETY STANDARDS	ORLEN S.A.
Version: January 2024	OCCUPATIONAL HEALTH AND SAFETY EXECUTIVE GUIDELINES FOR CONTRACTORS	Page no.: 5

2. Operational regulation regarding the plan of division and allocation of areas of ORLEN S.A. in Płock.

The operational regulation introduces the "Land Division Plan" within the Production Facility in Płock, between individual Land Owners, Land Tenants and the "Area Assignment Plan" within the Production Facility in Płock to proper Site Supervisors .

The basic unit of land division within the fenced area is a technological plot with a marking consisting of a letter and number (eg. D8).

The boundaries of the technological plot are curbs or main roads edges in accordance with the General Plan of ORLEN S.A.

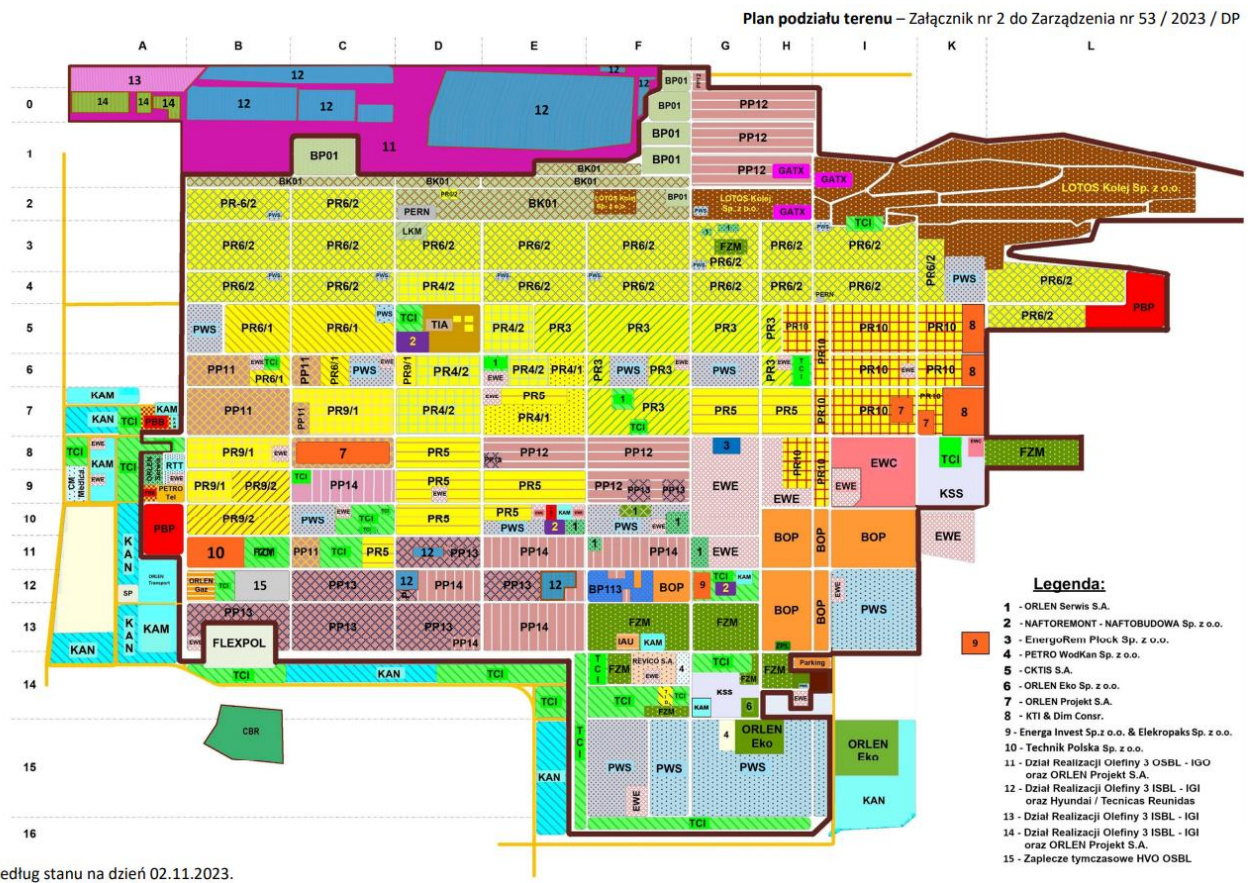



Fig. 1- Map of the Production Facility in Płock

	SAFETY STANDARDS	ORLEN S.A.
Version: January 2024	OCCUPATIONAL HEALTH AND SAFETY EXECUTIVE GUIDELINES FOR CONTRACTORS	Page no.: 6

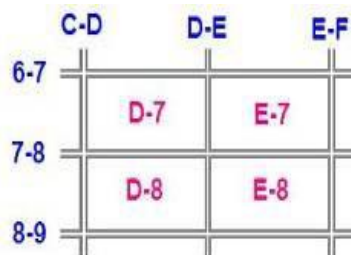

Fig. 2 Example of marking of roads and plots

The boundaries of the technological plot are precisely defined in the resources of the Geodetic and Cartographic Documentation Department of ORLEN S.A.

The Land Owner/ Tenant is responsible for maintaining the OHS, fire and environmental protection, cleanliness and order in the assigned area in accordance with the standards applicable at ORLEN S.A. on *maintaining the working order of fire protection equipment (ROP), fire alarm system (SSP), and providing information on repairs to the Head of the ICT Networks Department*, maintaining an "Area Inspection Book" (template document to be collected from the OHS Office), keeping records of entries and exits of persons who are not employees of the installation. The records may be kept in the form of a book or a board according to the template below:

Symbol of ORLEN S.A. organizational unit / Company's name	Name and surname (of the person or group leader), purpose of entering the installation	Total number of people	Entry (date, time)	Exit (date, time)

The owner of the main flyovers and trenches (structures without pipelines, communication routes, sewage systems and equipment) is the Technical Infrastructure and Renovation Settlements Department.

Technological pipelines, located on flyovers and in manifold trenches, are subject to individual managers of organizational units (production installations).

The flyovers and manifold trenches are assigned to the area of supervision to individual landowners independently of the basic unit of land division, which is the technological plot.

The Executive Director or the Office Director can establish an internal, detailed allocation (assignment) of the area to subordinate employees.

For technological plots used by investment services during the construction of new facilities as construction sites for facilities and infrastructure, back-up facilities, storage yards, etc., from the time of the protocolar transfer of the area to investment services until the site is tidied up and handed over by protocol to the user, Project Implementation Manager or Substitute Investor is appointed the Site Supervisor acting on behalf of ORLEN SA.

	<p style="text-align: center;">SAFETY STANDARDS</p>	<p style="text-align: center;">ORLEN S.A.</p>
<p>Version: January 2024</p>	<p style="text-align: center;">OCCUPATIONAL HEALTH AND SAFETY EXECUTIVE GUIDELINES FOR CONTRACTORS</p>	<p style="text-align: center;">Page no.: 7</p>

3. Regulation on the management of protective clothing, protective footwear, personal protection equipment, as well as the provision of personal hygiene equipment and means for providing first aid for individual work positions in ORLEN S.A.

The basis for equipping employees with individual protections is the Regulation on the management of protective clothing, as well as the provision of personal hygiene equipment and first aid means for individual work positions at ORLEN S.A., taking into account the nature of the work performed.

The Contractor is obliged to:



- equip employees with clothing, footwear and personal protective equipment in accordance with occupational risk assessment carried out to protect against existing threats,
- obligatory equip employees performing work outside office and social rooms in:
 - antistatic protective clothing, and in the case of hazardous works in terms of fire or in areas at risk of explosive atmospheres, in flame-retardant protective clothing,
 - class S3 SRC safety shoes with an antistatic sole, anti-puncture insert and toe cap, safety helmets with at least 3-point chin strap, safety goggles, protective gloves,
 - a protective helmet in the color depending on the scope of the duties performed by the employee, which will allow other persons to recognize his function from a further distance:
 - a. **white** for construction managers, supervision inspectors, auxiliary engineers, designers,
 - b. **orange** for masters, foremen, persons managing employees authorized to receive one-off permits,
 - c. **yellow** for manual workers,
 - d. **red** for people responsible for occupational health and safety, i.e. employees of the OHS service, OHS inspectors, OHS specialists, OHS coordinators,
 - e. **gray** for guests, apprentices, interns.
- in escape equipment selected for the occurring mass hazards, due to the possibility of announcing a chemical alarm. Escape equipment may be available in a place determined by the Contractor for immediate use in the event of announcing a chemical alarm, e.g. on hangers/stands.

Antistatic protective clothing may be used during:







- a. fire-hazardous work,
- b. works in zones at risk of an explosive atmospheres,

provided that the Job Safety Analysis (JSA) and fire and explosion risk analysis proves that there is no need to use flame-retardant protective clothing, and the person responsible for the object / installation on the part of the Employer and the Employer's OHS Service will not object.

 ORLEN	SAFETY STANDARDS	ORLEN S.A.
Version: January 2024	OCCUPATIONAL HEALTH AND SAFETY EXECUTIVE GUIDELINES FOR CONTRACTORS	Page no.: 8

Item	Specification	Requirements	Marking
1.	Protective clothing with antistatic and permanently flame-retardant properties	<p>Clothing should meet the requirements of the following standards:</p> <ul style="list-style-type: none"> • EN ISO 13688: 2013 Protective clothing - General requirements. • EN 1149:5:2018 Protective clothing. • Protective clothing - Electrostatic properties - Part 5: Material and construction requirements. • EN ISO 11612: 2015 Protective clothing - Clothing for protection against heat and flame - Minimum performance requirements. 	<ol style="list-style-type: none"> 1. Type of product 2. Manufacturer's brand name 3. Size of clothing according to EN ISO 13688:2013 4. The number of the standard the required clothing meets 5. Graphic sign and protection sign <div style="display: flex; justify-content: space-around; align-items: center;"> <div style="text-align: center;">  <small>EN 1149</small> </div> <div style="text-align: center;">  <small>EN ISO 11612</small> </div> </div> <ol style="list-style-type: none"> 6. Method of maintenance 7. Marking with the CE mark/ number of the certification body.
2.	Safety shoes	<p>Safety shoes must have:</p> <ul style="list-style-type: none"> • closed heel area, • antistatic properties – heel resistant to diesel, • anti-puncture insole, • toe cap providing protection against impact with energy of at least 100J and compression with a force of at least 10 kN, • a sole resistant to slippage at SRC level, • boot type shoes are recommended. 	CE marked
3.	Protective helmet with chinstrap; and for work at heights – helmet with four-point fastening of the chinstrap to the shell.	<p>Helmet designed for work in potentially explosive areas, meeting the requirements of EN 397 + A1: 2012 - Industrial safety helmets.</p>	CE marked
4.	Splinterguard glasses	<p>Glasses must meet the requirements of PN-EN 166:</p>	

 ORLEN	SAFETY STANDARDS	ORLEN S.A.
Version: January 2024	OCCUPATIONAL HEALTH AND SAFETY EXECUTIVE GUIDELINES FOR CONTRACTORS	Page no.: 9

	- glasses providing eye protection from solids' splashes.	2005 Personal eye protection - Requirements. Made in 1st optical grade.	CE marked
5.	Protective clothing for people entering the active switch chambers on the premises of ORLEN.	<ul style="list-style-type: none"> Protective clothing must meet requirements from pt.1 and from the EN 61482-2 standard min. class 1. Work under voltage - protective clothing against thermal hazards caused by an electric arc - Part 1-2: Research Methods - Method 2: Determination of protection class against electric arc of materials and clothing at forced application and a targeted electric arc (test chamber). 	CE marked, Graphic marking:  EN 1149  EN ISO 11612  EN 61482-2
6.	Protective clothing for people performing works where the contact with liquid chemical splashes is possible	People should wear protective clothing that meets the requirements from p.1 and from the EN 13034 + A1: 2010 type 6 Protective clothing against liquid chemicals - Requirements for clothing with limited effectiveness of protection against liquid chemicals (Type 6 and Type PB6 clothing). Type 6 protective clothing against splashing liquid protects against short-term contact with liquid chemicals and can be made of impregnated fabrics and nonwovens. It is characterized by lightness and airiness. Clothing that protects against accidental scattering of oil and solvents and against diluted acids and bases most often belongs to this group.	CE marked, graphic marking:  EN 1149  EN ISO 11612  EN 13034 (TYP 6)

For work that causes heavy contamination in areas with risk of fire or explosion, disposable overalls with antistatic properties (in accordance with EN 1149) and flame-retardant (meeting the EN ISO 11612 standard or made of non-woven material preventing the spread of fire and flame) may be used, e.g. in confined spaces, when washing the devices. The remaining parameters of

	SAFETY STANDARDS	ORLEN S.A.
Version: January 2024	OCCUPATIONAL HEALTH AND SAFETY EXECUTIVE GUIDELINES FOR CONTRACTORS	Page no.: 10

the coveralls, i.e. resistance to dust and chemicals, should be selected for the purpose of the occupational risk assessment.

All personal protective equipment, including safety shoes and protective clothing, must have a declaration of conformity in accordance with the Regulation of the European Parliament 2016/425 and the CE marking.

In addition, the Contractor should:

1. develop internal regulations for equipping employees with personal protective equipment, determining the type of clothing and footwear and other personal protective equipment with the expected period of use, which should be adapted to the working conditions, type and level of threats present at a given position, as well as the degree of soiling and deterioration of clothing and hygiene and sanitary requirements;
2. keep records of the personal protective equipment selected for the hazards occurring during works on the premises of ORLEN assigned to individual employees;
3. specify in the BIOZ plan and/or IBWR appropriate PPE selected for the work performed on the basis of an occupational risk assessment taking into account the conditions in a given workplace on the premises of ORLEN;
4. provide personal protective equipment to employees working on the premises of ORLEN that are appropriately selected for the hazards arising during a given job on the basis of an occupational risk assessment taking into account the conditions prevailing in a given workplace and the ergonomic and health requirements;
5. include in the OHS instructions at workplaces that require the use of personal protective equipment, information on the type of these measures necessary for use in the performance of work. The instructions should be understandable to employees and contain the rules for the use of personal protective equipment, its inspection and maintenance;
6. use properly selected PPE when performing a given activity / work in accordance with the occupational risk assessment during work performed on the premises of ORLEN;
7. use technically and visually efficient personal protective equipment as intended by the manufacturer;
8. on the premises of ORLEN, use protective clothing in accordance with the PN-EN-ISO 13688 standard and marked with the company's name. The clothing should protect against hazards arising during work and meet the requirements of relevant standards;
9. On the site of the renovated ORLEN installations, use S3 class footwear (compliant with e.g. EN ISO 20345) - equipped with a toe cap, anti-puncture insert, hydrocarbon-resistant and anti-electrostatic sole with an SRC class anti-slip factor;
10. Implement effective control activities to provide employees with personal protective equipment in good technical and visual condition.
11. Carry out documented periodic inspections of the technical condition of the PPE in accordance with the manufacturer's recommendations.
12. Strictly observe the period of use of PPE specified by the manufacturer, and immediately withdraw from use the means that lost their protective function before the expiry date during the hazardous event (e.g. a helmet after an impact, safety harness after restraining a fall from a height) or in other circumstances (e.g. as a result of improper storage or maintenance).

	SAFETY STANDARDS	ORLEN S.A.
Version: January 2024	OCCUPATIONAL HEALTH AND SAFETY EXECUTIVE GUIDELINES FOR CONTRACTORS	Page no.: 11

13. In the case of contamination of clothes on the premises of ORLEN with harmful substances, employees should wash their clothes in a specialized laundry room adapted to remove the stains in accordance with the manufacturer's instructions..
14. Provide employees with appropriate social rooms suitable for changing clothes and storing PPE, in accordance with the manufacturer's recommendations.
15. Provide for inspection by the OHS Coordinator and / or the OHS service of ORLEN / OHS supervision of ORLEN Eko the documentation confirming the fulfillment of the obligation to equip employees with appropriately selected PPE for works on the premises of ORLEN..
16. Perform risk assessment using the LMRA method, including PPE.

REMEMBER:

A. Whole body protection measures: pants, jackets, shirts, vests, coveralls, should:

- meet the requirements of specific standards, have a declaration of conformity and be marked with the CE mark, the number of the certification body and pictograms indicating the planned protection,
- be marked with the company name and logo (logo and company name marking does not apply to disposable coveralls) and be undamaged and uncontaminated - damage and contamination reduce the planned protective,
- be washed by a specialized laundry in accordance with the manufacturer's recommendations in the event of contamination with toxic substances - not applicable to disposable coveralls,
- be used and stored in accordance with the manufacturer's recommendations,
- be periodically inspected in accordance with the manufacturer's recommendations and eliminated from use in the event of loss of protection parameters or exceeding the service life recommended by the manufacturer.

B. Lower limb protection: footwear, e.g. boots, must:

- have an anti-puncture insole, toe cap, SRC class slip resistance, antistatic sole resistant to hydrocarbons,
- be a boot – type shoe, well-fitted, undamaged and in good technical condition as recommended by the manufacturer,
- be used, stored and maintained in accordance with the manufacturer's recommendations,
- undergo periodic inspection of their technical condition in accordance with the manufacturer's recommendations and must be eliminated from use in the event of damage, destruction or exceeding the period of use recommended by the manufacturer.

C. Head protection: protective helmets/ hard hats, must:

- have the CE mark and a legible production date,
- have a well-fitting chinstrap, which should always be used regardless of the high/level of work performed,
- be inspected by the user before each use, in accordance with the manufacturer's recommendations for damage, cracks in the helmet shell and other elements that make up the whole, and immediately after a dangerous impact to check for cracks or damage,
- be used, stored and maintained in accordance with the manufacturer's recommendations,
- be withdrawn from use when found to be damaged or after the period of use specified by the manufacturer has been exceeded.

D. Eye and face protection: splash goggles, face shields, must:

- have the CE mark and be made in the 1st optical class in accordance with PN-EN 166,
- be in good technical condition and not be contaminated, ensure good visibility,

	SAFETY STANDARDS	ORLEN S.A.
Version: January 2024	OCCUPATIONAL HEALTH AND SAFETY EXECUTIVE GUIDELINES FOR CONTRACTORS	Page no.: 12

- be adapted to the employee, if the employee uses corrective glasses – be suitable for use with corrective glasses - not all glasses are suitable for wearing together with corrective glasses, it is possible to wear corrective – protective glasses,
- be used, maintained and stored in accordance with the manufacturer's recommendations,
- be inspected by the user before each use, in accordance with the manufacturer's instructions, and withdrawn from use after noticing any damage, cracks, scratches causing limited visibility or failure to follow the maintenance and storage recommendations.

E. Upper limb protection: protective gloves, must:

- be selected for the risks in accordance with the occupational risk assessment for the work performed,
- undamaged and in good technical condition,
- used, maintained and stored in accordance with the manufacturer's recommendations,
- be inspected by the user before each use in accordance with the manufacturer's instructions and withdrawn from use after noticing any damage, cracks or failure to follow the manufacturer's instructions related to cleaning, maintenance and storage.

F. Hearing protection: hearing protectors (disposable earplugs, reusable earplugs, helmet earplugs) must:

- be selected according to the noise level and adapted to the user and other personal protective equipment that should be used during the work,
- undamaged and in good technical condition,
- used, maintained and stored in accordance with the manufacturer's recommendations,
- be inspected by the user before each use in accordance with the manufacturer's instructions and withdrawn from use after noticing any damage, cracks or failure to follow the manufacturer's instructions related to cleaning, maintenance and storage.

G. Respiratory system protection equipment: escape equipment - for evacuation purposes, respiratory tract isolating devices (breathing apparatus - closed system, self-contained breathing apparatus) must:

- have the CE marking and have valid periodic documented inspections in accordance with the manufacturer's recommendations,
- be selected in accordance with the performed risk assessment,
- be in good technical condition,
- used, maintained and stored in accordance with the manufacturer's recommendations,
- be checked by the user before each use, according to the manufacturer's recommendations,
- be withdrawn from use in accordance with the manufacturer's recommendations.

H. Fall protection measures: safety harness, fall arrest devices, shock absorbers, lanyards, anchor components must:

- have CE marking and valid periodic documented inspections in accordance with the manufacturer's recommendations,
- be selected in accordance with the occupational risk assessment carried out - when the free fall path is less than 6m, self-locking devices should be used as a connecting and shock-absorbing unit, when working on poles, devices for working in support should be used - elements of a protective system that will determine the position when working at height,
- be in good technical condition, undamaged, not torn, not contaminated with chemicals,

	SAFETY STANDARDS	ORLEN S.A.
Version: January 2024	OCCUPATIONAL HEALTH AND SAFETY EXECUTIVE GUIDELINES FOR CONTRACTORS	Page no.: 13

- used, maintained and stored in accordance with the manufacturer's recommendations,
- be checked by the user before each use, according to the manufacturer's recommendations,
- be withdrawn from use after a fall arrest and in other cases according to the manufacturer's recommendations.

4. Safe use of mobile communication devices, including mobile phones and other portable multimedia devices. in the production and logistics facilities of ORLEN S.A.

It is forbidden to use and carry mobile communication devices, including mobile phones and other portable multimedia devices, on the premises of ORLEN. The prohibition applies to:

- 1.1. Areas with **explosion hazard zones**, for devices without Ex certificates, as appropriate for a given zone due to explosion hazards.
- 1.2. **Buildings or their special rooms** where there is a possibility of disrupting the operation of electronic and power electronic devices, signal paths crucial for the continuity of operation and the safety of production and logistics installations.
- 1.3 It is assumed that: "Mobile communication devices" is a portable electronic device that allows you to receive, send and process data without the need to maintain a wired connection to the network, connection and data transmission is mainly via GSM, WiFi, Bluetooth, AirPlay (and equivalent) and radio network ((TETRA, VHF, UHF); "Portable multimedia devices" are all other devices not listed as mobile communication devices, but enabling interaction with the user other than required for work-related tasks.

The prohibition does not include:

- electrical switchboards and other rooms containing microprocessor devices with declarations of compliance with the safety and electromagnetic compatibility requirements specified in EU Directive 2014/30EU, with the exception of places covered by an explosion hazard zone,
- installations undergoing renovation after informing external contractors about this fact in writing, e.g. via information boards, or verbally during renovation meetings for a given organizational unit,
- an installation in technological operation, provided that a mobile communication device in a standard version is added to the equipment used in the one-off permit for particularly hazardous work involving open flame,
- using mobile and multimedia communication devices (telephones, tablets, radiotelephones) with an increased level of explosion, fire and anti-jamming safety approved by ORLEN S.A.

List of explosion-proof mobile communication devices approved for use in areas with explosion hazard zones and in buildings and special rooms of buildings on the premises of ORLEN S.A. is available at the link:

<https://www.orken.pl/pl/o-firmie/o-spolce/nasze-standardy/bezpieczenstwo-w-orkenie/wykonawcy-zewnetrzni/aktualnosci>

 ORLEN	SAFETY STANDARDS	ORLEN S.A.
Version: January 2024	OCCUPATIONAL HEALTH AND SAFETY EXECUTIVE GUIDELINES FOR CONTRACTORS	Page no.: 14

5. Regulation regarding the procedure for establishing the circumstances and causes of accidents at work, accidents on the way to or from work, occupational diseases and work safety hazards as well as the procedure for ensuring care for victims of accident events at work at ORLEN S.A.

Each employee is obliged to report all accident events that took place at work to the:

- Company Fire Brigade – ORLEN Production Facility in Płock: **19 998**
- Company Fire Brigade – CCGT and PTA Facilities in Włocławek: **19 998, 19 112**
- Company Fire Brigade - Orlen Południe Production Facility in Trzebinia: **10 300** (from landline phones)
- At fuel terminals - the person managing the terminal,



Each employee has the opportunity to report work safety hazards in the form of:

- text message to number **605 608 888**:
 - ✓ If you are in a place where you can not use a mobile phone - move away where it is allowed (administrative building, main road).
 - ✓ If you are in a place where you can use your phone - do not wait! Send notification!
 - ✓ Send a text message to number 605608 888 with the following informations: name and surname, company name, location where the danger occur, description of the threat, description of corrective actions.
- send an e-mail to the following address: bhp@orlen.pl.

An accident event is any event which occurs during the performance of tasks within normal work time resulting in injury which requires medical help.

An accident at work is an incident which:

- **is sudden,**
- **is caused by an external factor,**
- **results in injury or death,**
- **occurs in relation to work.**

During the workday following the accident, the manager of the organizational unit collects necessary data to complete the Post-accident Report and collects materials which will constitute accident documentation (accident at work report card, written explanations and informations, representations, evidence, etc.).

The main task of the Post – accident Team is to determine:

- **whether the accident meets the requirements of the definition of an accident at work,**
- **circumstances and causes of the accident at work,**
- **preventive conclusions thereof and preparation of post-accident Report.**

The external contractor whose employee has suffered an accident on the premises of ORLEN appoints the Post – accident Team. Employees of the Group OHS and Prevention Coordination Department of ORLEN may participate in post-accident proceedings at the request of the contractor.

	SAFETY STANDARDS	ORLEN S.A.
Version: January 2024	OCCUPATIONAL HEALTH AND SAFETY EXECUTIVE GUIDELINES FOR CONTRACTORS	Page no.: 15

In order to eliminate cases in which the victim will remain in damaged protective clothing, often without outer clothing (in winter) and without documents and money to return home or business after leaving the hospital, he should be provided with proper care.

6. Regulation regarding the Work Safety Day in the ORLEN S.A.

The first Thursday of each month is the Work Safety Day (DBP) at ORLEN SA. If the first Thursday of the month falls on a statutory holiday, then the Work Safety Day (DBP) is the next Thursday taking place on a workday. On this day, all employees equipped with fully completed escape equipment are obliged to carry them with them (remember to periodically check the mentioned masks in the applicable periods – authorized persons). It also applies to the CCGT Facility in Włocławek and construction sites run by ORLEN SA.

7. Regulation regarding principles, scope and implementation of training in the field of occupational health and safety and other obligatory training at ORLEN S.A. and the method of their documentation.

Training for employees of another employer performing works on the premises of ORLEN S.A.

Training on hazards occurring at the Production Facility in Płock and the PTA Facility in Włocławek (theoretical knowledge and practical skills testing) is obligatory for external entities conducting activity or providing work for ORLEN S.A. and is implemented by the OHS Office, the Company Fire Brigade, ORLEN Eko Sp. z o.o. and by ORLEN S.A. Training Center, at the request of the contractor of works for ORLEN S.A. Employees of external companies, performing works for ORLEN S.A., receive a referral for training on hazards to the Group OHS and Prevention Coordination Department, ORLEN Eko Sp. z o.o. or ORLEN S.A. Training Center from the ordering party.

Training on hazards occurring at the Production Facility of ORLEN SA in Płock, the PTA Facility in Włocławek and CCGT Włocławek are conducted on Mondays and Fridays each week at the OHS Office building in the room No. 4, (if they are not statutory holidays). The training starts at 8.00 and lasts 2 hours. If more employees of external entities apply for one training than the maximum permissible number of participants, additional dates of training will be temporarily launched depending on the needs.

Training on hazards occurring at the ORLEN SA Production Facility of in Płock, the PTA Facility in Włocławek and the CCGT Włocławek Facility for foreigners are conducted after receiving a referral for the training to the Group OHS and Prevention Coordination Department from the ordering party and confirmed by the Control and Safety Office, and setting an individual date of training.

The date of training for employees employed outside the Production Facility in Płock and the PTA Facility in Włocławek ORLEN S.A. are determined by the managers of organizational units with employees of ORLEN Eko Sp. z o.o.

Training on hazards provided by ORLEN Eko for persons implementing contracts at fuel terminals is free.

The Contractor is obliged to:

- perform additional, outside instruction about the risks carried out by the Employer, training for employees and subcontractors (their, further and other persons working for them) in the field of occupational health and safety as well as fire and process safety before

	SAFETY STANDARDS	ORLEN S.A.
Version: January 2024	OCCUPATIONAL HEALTH AND SAFETY EXECUTIVE GUIDELINES FOR CONTRACTORS	Page no.: 16

commencing work at ORLEN SA, taking into account the specifics of this work and the conclusions of the occupational risk assessment carried out, and to document these trainings due to: program, lecturers, time frames and practical aspects.

- provide employees acting on its behalf with alarm procedures in the event of fire, emergency and other local threats as well as evacuation:
 - a) on the premises of the Production Facility in Płock – contact the ORLEN Company Fire Brigade in Płock,
 - b) on the premises of the PTA Facility in Włocławek – contact the Anwil S.A. Company Fire Brigade in Włocławek,
 - c) on the premise of the Fuel Terminach in Trzebinia – contact the Orlen Południe S.A. Company Fire Brigade,
 - d) at any other Fuel Terminal – contact the State Fire Brigade.

Confirmation of completion of the informational training on hazards is the "Certificate for employees of another employer, performing work on the premises of ORLEN S.A." received personally by the trainee. The training is valid for one year. Additionally, an English translation of the certificate is allowed for foreigners.

Turnaround Inserts

Before commencing any renovation works during the turnaround, the Subcontractor's obligation is to register the supervision staff and the OHS services for an **INTRODUCTORY** training conducted by the Orlen EKO safety inspectors and to provide a complete set of documents, i.e. appraised - approved IBWR (Instructions for safe execution of works), OHS Declaration, attendance list of the contractor's supervision and OHS services at the introductory training in connection with the plant turnaround (training on local hazards), attendance list for the training regarding performing particularly hazardous works on the premises of the plant for persons employed at workers' positions, Excel file with data of all employees.

Step 1

INTRODUCTORY (pre-renovation) training for supervisory and OHS service personnel performing renovation works at the Production Facility in Płock is conducted on Wednesdays and Fridays each week in Building 01 (Orlen Eko) in the Training Room (if they are not public holidays). In situations where more employees of external entities are registered in one training than the maximum allowable number of participants, additional training is temporarily launched, depending on the needs.

Employees registered for the INTRODUCTORY training must have a training list with them. Due to two variants of informational hazard training for external employees (obtaining a pass to enter the Production Facility in Płock)

- 1) ORLEN S.A. Training Center („computer” training)
- 2) ORLEN S.A. Safety Office

two sets of lists are required for the **INTRODUCTORY** training:

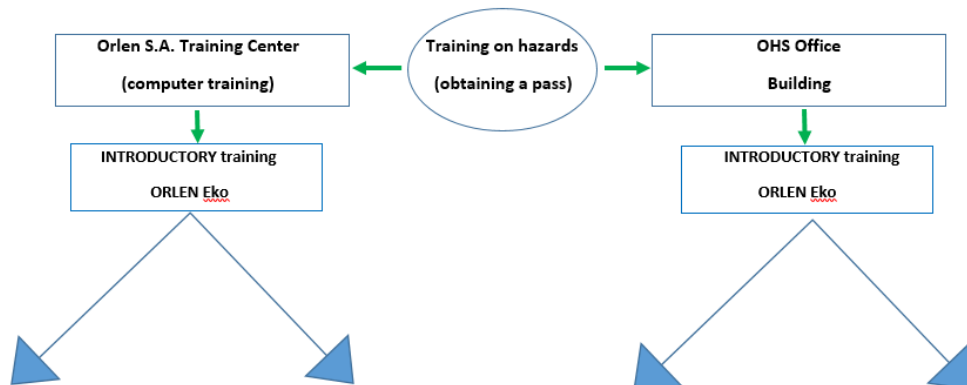

Appendix no. 1

Appendix no. 2

Appendix no. 1

Appendix no. 3

Załącznik nr 1

LISTA OBECNOŚCI NAZDORU I SŁUŻB BHP WYKONAWCÓW NA SZKOLENIU WPROWADZAJĄCYM W ZWIĄZKU Z REMONTEM NA TERENIE INSTALACJI

W FIRME: ORLEN, data szkolenia: 01.01.2024

Lp.	Imię i Nazwisko	Stanowisko	Przebieg	Adres e-mail	Nr tel. kontaktowego	Podpis
1.	Adamowski Adam	Inżynier	Nowa			
2.	Bogdanowski Bogdan	Kierownik odd.	Nowa			
3.	Kowalski Karol	Inżynier	Nowa			
4.	Kowalski Michał	Inżynier	Nowa			
5.	Nowak Adam	Inżynier	Nowa			
6.	Stankowski Stanisław	Inżynier	Nowa			

Data szkolenia: podpis przebiegu ORLEN S.A.

*Wzrostek alfabetyczny oznacza sposób wyliczenia porządkowania alfabetycznego.

Załącznik nr 2

LISTA OBECNOŚCI NA SZKOLENIU DOTYCZĄCYM SPOSOBU WYKONYWANIA PRAC SZCZEGÓLNIE NIEBEZPIECZNYCH NA TERENIE INSTALACJI

W FIRME: ORLEN, data szkolenia: 01.01.2024

Lp.	Nazwisko i imię	Stanowisko	Podpis
1.	Adamowski Adam	inżynier	
2.	Barczowski Bartosz	inżynier	
3.	Hubertowski Robert	SPRAWCZ	
4.	Rotowski Piotr	SPRAWCZ	

Data szkolenia: podpis przebiegu

Nazwisko i imię: _____

Załącznik nr 1

LISTA OBECNOŚCI NAZDORU I SŁUŻB BHP WYKONAWCÓW NA SZKOLENIU WPROWADZAJĄCYM W ZWIĄZKU Z REMONTEM NA TERENIE INSTALACJI

W FIRME: ORLEN, data szkolenia: 01.01.2024

Lp.	Imię i Nazwisko	Stanowisko	Przebieg	Adres e-mail	Nr tel. kontaktowego	Podpis
1.	Adamowski Adam	Inżynier	Nowa			
2.	Bogdanowski Bogdan	Kierownik odd.	Nowa			
3.	Kowalski Karol	Inżynier	Nowa			
4.	Kowalski Michał	Inżynier	Nowa			
5.	Nowak Adam	Inżynier	Nowa			
6.	Stankowski Stanisław	Inżynier	Nowa			

Data szkolenia: podpis przebiegu ORLEN S.A.

*Wzrostek alfabetyczny oznacza sposób wyliczenia porządkowania alfabetycznego.

Załącznik nr 3

LISTA OBECNOŚCI PRACOWNIKÓW WYKONAWCÓW NA SZKOLENIU WPROWADZAJĄCYM ORAZ Z ZAGROZAMI LOKALNYCH WYSTĘPUJĄCYCH NA TERENIE INSTALACJI

W FIRME: ORLEN, data szkolenia: 01.01.2024

Nazwa firmy: ORLEN

Szkolenie dla Służby BHP, nadzoru i pracowników Wykonawców.

Lp.	Nazwisko i imię	Nazwisko (lub pseudonim) pracownika ORLEN	Data szkolenia	Capitula podpis
1.	Adamowski Adam	N	01.01.2024	
2.	Adamowski Adam	1.3	01.01.2024	
3.	Barczowski Bartosz	1.3	01.01.2024	
4.	Bogdanowski Bogdan	N	01.01.2024	
5.	Hubertowski Robert	1.3	01.01.2024	
6.	Kowalski Karol	N	01.01.2024	
7.	Kowalski Michał	N	01.01.2024	
8.	Nowak Adam	N	01.01.2024	
9.	Rotowski Piotr	1.3	01.01.2024	
10.	Stankowski Stanisław	N	01.01.2024	

Data szkolenia: podpis przebiegu ORLEN S.A.

*Wzrostek alfabetyczny oznacza sposób wyliczenia porządkowania alfabetycznego.

Step 2

After completing the **INTRODUCTORY** training for supervisory and OHS service personnel, the Contractor's supervisory representative trained this way is obliged to pass on the training content to other persons employed at workers' positions.

Step 3

The training list in *Appendix No. 2* is dedicated to employees at workers' positions who completed training at the Orlen S.A. Training Center (computer training). One of the scopes of this training are local hazards at the production facilities during the turnaround. The training list in *Appendix No. 3* is dedicated to employees who completed hazard training in the Occupational Health and Safety Office. Additionally, these employees must be trained by the supervision of the renovation external Company in hazards based on materials provided by the supervision of the Installation – the Safety Card. Training lists should be filled with employee data in alphabetical order, starting with surname.

An example of the Safety Card:

	SAFETY STANDARDS	ORLEN S.A.
Version: January 2024	OCCUPATIONAL HEALTH AND SAFETY EXECUTIVE GUIDELINES FOR CONTRACTORS	Page no.: 18

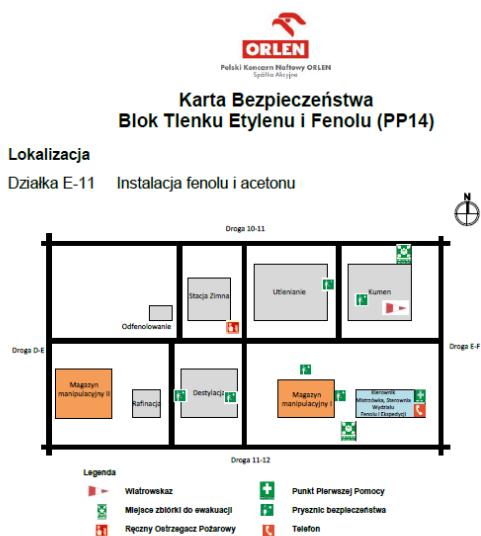

Główne zagrożenia na instalacji



- Węglowodory aromatyczne i alifatyczne – palne, gorące, toksyczne, mutagenne
- Wodór, propylen – palne, wybuchowe
- Chemikalia: ług sodowy, kwas siarkowy – żrąco-parzący
- Rurociągi, aparaty oraz urządzenia wirujące – wysokie temperatury i ciśnienia

Karta Bezpieczeństwa Bloku Tlenku Etylenu i Fenolu (PP14), Działka E-11

Zagrożenia z instalacji sąsiadujących

- Rejon II zagrożenia chemicznego:
- gazy płynne
 - siarkowodór

Na terenie instalacji obowiązuje

- wykonywanie prac tylko na podstawie wystawionych zezwoleń
- wjazd na teren instalacji tylko na podstawie pisemnego zezwolenia
- bezwzględny zakaz operowania armaturą na rurociągach i aparatach
- bezwzględny zakaz palenia tytoniu i używania telefonów komórkowych
- zakaz spożywania napojów alkoholowych i zażywania środków odurzających
- noszenie odzieży i obuwia ochronnego w wykonaniu antyelektrostatycznym
- używanie kasków, okularów i rękawic ochronnych

Każdy kto zauważy wypadek, pożar, awarię lub inne miejscowe zagrożenie zawiadamia Zakładową Straż Pożarną

- telefonicznie – Zakładowy Telefon Ratunkowy w Plocku



- Ręcznym Ostrzegaczem Pożarowym - zbici szybko, nacisnąć przycisk, potwierdzić telefonicznie – 19 998

Nadzór Instalacji Fenolu 24 256 54 37 24 256 76 23

Mistrz procesów produkcyjnych 24 365 34 01

Alarm chemiczny

Ogłoszenie alarmu: Obywa się za pomocą syreny alarmowej lub buczka, modulowanymi sygnałami dźwiękowymi trwającymi 3 minuty.

POSTĘPOWANIE PO OGŁOSZENIU ALARMU CHEMICZNEGO

- zabrać maskę przeciwgazową
- przemieszczać się prostopadle do kierunku wiatru do Miejsca Zbiórki do Ewakuacji
- po przybyciu do Miejsca Zbiórki do Ewakuacji zameldować się u kierującego akcją ratowniczą i postępować zgodnie z jego poleceniami

Odwołanie alarmu: sygnał ciągły trwający 3 minuty

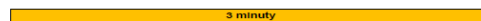

Karta Bezpieczeństwa Bloku Tlenku Etylenu i Fenolu (PP14), Działka E-11

Step 4

In order to issue the turnaround inserts enabling entry on the premises of the renovation site, in addition to providing a complete set of documents, i.e. IBWR (Instructions for safe execution of works), OHS Declaration, attendance list of the contractor's supervision and OHS services (Appendix no. 1), attendance list for persons employed at workers' positions (Appendix no. 2 or 3), please attach a properly completed Excel file. Example below.

Nadzór (N)/pozostali pracownicy (-)	Nazwa Instalacji	Imię i Nazwisko	Podwykonawca/ dla kogo	Nr przepustki	Wykonawca	Stanowisko	Numer ID E-Pracuj
N	HOG	Adamski Adam	ORLEN S.A	123456	Nova	Służba BHP	1111
(-)	HOG	Adamski Adrian	ORLEN S.A	456789	Nova	Monter	2222
(-)	HOG	Bartoszewski Bartosz	ORLEN S.A	45357547	Nova	Monter	3333
N	HOG	Bogdanowski Bogdan	ORLEN S.A	35635636	Nova	Kierownik robót	4444
(-)	HOG	Hubertowski Hubert	ORLEN S.A	465675	Nova	spawacz	5555
N	HOG	Kowalski Karol	ORLEN S.A	4634636	Nova	brygadzysta	6666
N	HOG	Kowalski Michał	ORLEN S.A	463463	Nova	brygadzysta	7777
N	HOG	Nowak Adam	ORLEN S.A	6346346	Nova	brygadzysta	8888
(-)	HOG	Piotrowski Piotr	ORLEN S.A	64574563	Nova	spawacz	9999
N	HOG	Stanisławski Stanisław	ORLEN S.A	466336356	Nova	brygadzysta	121212

After providing a complete set of documents by e-mail, the time needed to verify submitted documents and issue the Turnaround inserts is 2 business days.

Applications for the training: e-mail: karolina.pycek@orlen.pl; tel: +48 693 061 642

	SAFETY STANDARDS	ORLEN S.A.
Version: January 2024	OCCUPATIONAL HEALTH AND SAFETY EXECUTIVE GUIDELINES FOR CONTRACTORS	Page no.: 19

Checking the qualifications of employees of external companies in the ORLEN S.A. Training Center

Employees of external companies performing works on the premises of the Production Facility in Płock, CCGT Włocławek and PTA Facility in Włocławek, on the basis of renovation, service and framework contracts for ongoing maintenance, are subject to theoretical and practical verification at the Training Center. 100% of the Contractors' employees and their subcontractors dedicated to work at production plants in Płock and Włocławek will be subject to theoretical verification.

At least 25% of the Contractor's employees and its subcontractors dedicated to work in the mechanical and electrical industries at the production plants in Płock and Włocławek will be subject to practical verification.

A positive result of the verification entitles to obtain a personal pass, allowing to enter the premises of the ORLEN S.A. production plants. The training is valid for 1 year (the pass is personal and issued to the company). A negative result of the verification results in a ban on entering the premises of the plants for a period of 3 months. After the grace period, the employee may re-attempt the verification.

In addition, the Contractor, apart from the instruction on hazards conducted by the Ordering Party, carried out by OHS and CFB of ORLEN S.A., ORLEN Eko Sp. z o.o. and by the ORLEN S.A. Training Center:

- declares that its employees performing works at the premises of ORLEN S.A. have current medical reports on the absence of health contraindications to perform these works;
- declares that the employees acting on its behalf have qualifications appropriate to the type of works performed on the premises of ORLEN S.A.
- undertakes to provide employees with medical care and to organize care for an employee injured in an accident event occurring while performing works at ORLEN S.A.
- in the event of the working conditions not corresponding to the provisions of occupational safety and fire protection and posing a direct threat to the health and life of the Contractor's employee or if his work threatens such danger to other persons, the Contractor's employee has the right to refrain from performing work, immediately notifying his supervisor.

If refraining from performing work does not remove said threat, the Contractor's employee has the right to move away from the danger site, immediately notifying his supervisor. The Contractor is obliged to inform the Ordering Party about the threat and suspension of work.

The Contractor's employees are obliged to immediately report identified occupational safety hazards occurring in the area covered by the works, as well as throughout the entire organizational unit and / or installation. Information about the noticed hazards should be provided to the persons responsible for the organizational unit and / or installation on the part of the Employer or the Employer's OHS Service.

8. Regulation on the application of the Process Safety Management System at the ORLEN S.A.

The Process Safety Management System is part of the overall management system at ORLEN SA. The Production Facility in Płock, the PTA Facility in Włocławek and the Company's fuel terminals have been classified as an increased or high hazard worksites (upper-tier establishments). All classified facilities have documentation adequate to the classification of:

- registration of the Facility
- Prevention Program

 ORLEN	SAFETY STANDARDS	ORLEN S.A.
Version: January 2024	OCCUPATIONAL HEALTH AND SAFETY EXECUTIVE GUIDELINES FOR CONTRACTORS	Page no.: 20

And for high-risk worksites also:

- Safety Report
- Internal Operation and Rescue Plan

9. Regulation concerning the implementation of works based on written permits at the Production Facility in Płock, PTA Facility in Włocławek, CCTG Facility in Włocławek and the Fuel Terminals located outside Płock.

Works carried out on the basis of written permits include:

- hot works,
- works delivered inside tanks and confined spaces,
- works related to opening tanks, pipelines and devices after emptying and neutralization,
- work in drains,
- work at heights,
- earthworks,
- work using hazardous materials,
- works carried out in the vicinity of unprotected electric power equipment or parts of it, under voltage,
- carried out with power devices disconnected from voltage, but grounded in such a way that any of the earthing is not visible from the place of work,
- maintenance, renovation or assembly at unloading devices for liquid and gas fuels,
- renovation and investment works,
- other work not included in the applicable instructions.

Types of written permits in ORLEN SA:

- long-term permit:
 - ✓ for renovation works,
 - ✓ for investment works,
 - ✓ for hot works for workshop facilities and permanent fixtures of contractors.
- one-off permit:
 - ✓ to perform particularly hazardous works,
 - ✓ vehicle entry permit,
 - ✓ for other works.

The obligation to provide information about the contract number or the order number from the INFOR system rests with the Contractor, the contract number is listed in the Annex No. 13 - NAME LIST OF STAFF MEMBERS OF THE EXECUTIVE TEAM or will be generated in the e-PTW Electronic Permit Issuing System. If the contract number or the order number from INFOR (D7i) system is not provided, the Permit may not be issued. Works that will be performed under one-off permits issued by production installations require the creation of a user account (to collect permits) in the Electronic Permit Issuing System. Please contact the administrators of the e-PTW to add your Employees to the system: administrator.eptw@orlen.pl.

Attachments 5-7 - forms for one-off permits.

For works related to a specific main pipeline and main cable routes (renovation, extension, dismantling, etc.). the permit is issued and approved by it's owner after agreeing on the safety conditions with the owner of the area where the works are being carried out.

For works related to the new main pipeline, a one-off permit is issued by the owner of the pipeline on which the works are carried out, in agreement with the land Owner. In areas permanently

	SAFETY STANDARDS	ORLEN S.A.
Version: January 2024	OCCUPATIONAL HEALTH AND SAFETY EXECUTIVE GUIDELINES FOR CONTRACTORS	Page no.: 21

excluded from production and transferred for investment works, one-off permits are issued by the Owner of the Site in agreement with the Investor's representative performing the task.

The basis for commencement of works is the approved permit and fulfillment of the safety conditions contained therein. It is not required to issue a written permit for activities related to saving lives and firefighting operations. In this case, the operator of the rescue operation is responsible for the selection of security measures.

The Supervisor and/ or the Approver (person approving the permit) have the right to refuse the permit and the Contractor of the works to not accept the permit or refrain from performing work until the existing obstacles are removed, if the planned manner of work performance or security conditions specified in the permit are not sufficient for safe performance of work and directly threaten the health and life of the employees or third persons who perform it; or if the permit is illegible. If necessary, they present and justify their position in writing.

It is allowed to carry out particularly dangerous works on the basis of a long-term permit for investment works, provided that:

- carrying out work on facilities disconnected from the system of active technological pipelines and the industrial network of the system I and II, in the case of other sewage networks, they should be secured in accordance with the method adopted for carrying out work using open fire,
- carrying out works at a distance of more than 30 m from devices containing toxic or flammable media (not applicable to pipelines on flyovers, in dumps and devices in Fuel Terminals, with appropriate safeguards),
- taking into account the requirements of ORLEN in-house regulations (regarding one-off permits, works inside tanks, earthworks, etc.),
- introduction by the Contractor of a documented system for carrying out hazardous works, in accordance with the requirements of ORLEN,
- immediate verification of the permit requirements in the event of any technical and organizational changes.

In individual cases, the decision to carry out particularly hazardous work on the basis of a long-term permit for renovation works is made by the Area Director, after seeking the opinion of the relevant Process Safety Committee.

Belayer on the part of the Contractor is responsible for:

- a) checking compliance with the permit conditions,
- b) performing visual inspection of the work site and ensuring their safe implementation, the belayer himself should not perform the work that he supervises if it prevents him from being in constant visual contact with other employees
- c) immediate discontinuation of works, if any threads or informations about them are found, that reduce the degree of safe performance of work specified in the authorization or gross violation of applicable provisions and principles of occupational health and safety and fire protection.
- d) control of the correct use of the LOTO System in accordance with the " LOTO instruction of ORLEN S.A." and the detailed "LOTO Instruction..." for a specific organizational unit / facility in which the system operates.

The one-off permit is issued for one shift, respectively for the work system that is used when carrying out the work.

If the safety conditions do not change and the work is carried out and supervised by the same persons listed in the issued permit, the permit may be extended. In this case, the Supervisor has

	SAFETY STANDARDS	ORLEN S.A.
Version: January 2024	OCCUPATIONAL HEALTH AND SAFETY EXECUTIVE GUIDELINES FOR CONTRACTORS	Page no.: 22

the right to extend the permit for a period of no more than 4 hours. The total validity period of the permit must not exceed 12 hours.

Each point of the permit must be filled in legibly by hand or using a computer. Deletions, additions, etc. are not allowed.

In points not affecting the safety of work, it is recommended to use the term "does not occur".

When there is a possibility to set a fire by accident, because of a long period of free fire development and difficulties in detecting it, several inspections of the workplace after its completion are required.

A vehicle entry permit may be issued for one vehicle only. During the performance of complex repair works, it is possible to issue a permit for vehicle entry for few days.

The electronic permit system is in force at ORLEN. In order to obtain a work permit or vehicle entry permit, the contractor confirms the permit conditions in the electronic system. It is necessary for him to have a individual login and password to the system. The login and password are granted by the system administrator on the basis of information sent from the Company (to the administrator.eptw@orlen.pl address) or the Contractor's statement. The Contractor sets the password himself during the so-called first login (then the starting password is changed to his own) on the ORLEN's computer at the place where permits are issued.

Anyone who notices any violations of applicable provisions and rules of occupational health and safety and fire protection while carrying out works on the premises of ORLEN S.A. is obliged to reprimand that employee and immediately notify the persons supervising the implementation of works.

The right to suspend the works referred to above is granted to:

- the permit's Approver and his superiors at all levels
- the Supervisor
- the Belayer
- the Contractor
 - ✓ authorized employees of the Company Fire Brigade,
 - ✓ employees of the Occupational Health and Safety Office performing tasks of the OHS and fire protection services,
 - ✓ OHS and fire prevention services of ORLEN Eko Sp. z o.o.,
 - ✓ Supervision Inspector supervising the implementation of works,
 - ✓ Company Social Labor Inspector,
 - ✓ Project Implementation Manager supervising the implementation of works,
 - ✓ any person who notices a threat to human life or health.

The decision about the re-commencement of works is made by the person approving the permit. In ORLEN a dangerous energy blocking system (LOTO System) is used, which eliminates accidental and uncontrolled switching on machines or release of dangerous energy during:

- operations,
- investment works,
- maintenance and repair.

The main elements introduced by the LOTO system are temporarily or permanently bringing the device or machine to a state where it is not supplied with energy (zero energy state), putting locks in places with cut-off energy (LOCKOUT) and marking their location - (TAGOUT). The system is based on assemble blocking.

	<p style="text-align: center;">SAFETY STANDARDS</p>	<p style="text-align: center;">ORLEN S.A.</p>
<p>Version: January 2024</p>	<p style="text-align: center;">OCCUPATIONAL HEALTH AND SAFETY EXECUTIVE GUIDELINES FOR CONTRACTORS</p>	<p style="text-align: center;">Page no.: 23</p>

10. Regulation regarding work at heights at ORLEN S.A.

Work at heights - work performed on a surface positioned at at least 1.0 m above the ground level.

Work with the use of ladders - the main purpose of ladders is vertical communication. They cannot be used for any other purpose than they were designed for, e.g. as a permanent place to work, support scaffolding or platforms, or horizontal communication routes.

Before deciding on the use of ladders as a workstation for temporary work at height, the Contractor is required to carry out a job safety analysis (JSA). It will specify the safety measures necessary to protect against falls from a height, taking into account i.a. the type of work carried out, the load on a given communication route, and the effectiveness of the measures already used to protect against falling from a height.

Before starting work, make sure that ladders used to carry out the work are:

- a) certified for a given job, their technical condition does not raise any objections, and the date of technical inspection is valid,
- b) regularly checked for safety,
- c) set on a stable, horizontal surface, ensuring their stability and a fixed point of support,
- d) positioned so that workers do not have to lean out in a way that could make the ladder unstable.

Principles of safe work from ladders:

- every work on a ladder requires the assistance of another person,
- stepladders should be used for work, with an efficient lock against folding and in good technical condition,
- do not use a ladder if a single task at that location will take more than 30 minutes for the worker to complete. In such a situation, working platforms, scaffolding or basket lifts should be used,
- the maximum working height of the ladder is 4m. In a situation where it is not possible to use scaffolding or a basket lift, the work manager may allow the use of longer ladders while maintaining safety measures resulting from the job safety analysis (JSA) prepared for this work and the provisions of this standard;
- only one person may be on the ladder at a time. If work must be done by more than one person, a second ladder, scaffolding or other dedicated work platform should be used.

Principles of safe work from leaning ladders:

- Work from leaning ladders is allowed only with the assistance of another person and meeting other requirements concerning them, listed below. The implementation of all works from leaning ladders applies only to temporary works,
- it is not allowed to carry out works requiring physical strength and involving both hands using ladders,
- it is not allowed to work with power tools from leaning ladders.

Principles of safe work from platforms / mobile platforms / self-propelled platforms:

- It is forbidden to attach fall protection equipment to mobile platforms.

	SAFETY STANDARDS	ORLEN S.A.
Version: January 2024	OCCUPATIONAL HEALTH AND SAFETY EXECUTIVE GUIDELINES FOR CONTRACTORS	Page no.: 24

Work at heights does not include works on the surface, regardless of the height on which it is located, if the surface:

- is protected from all sides up to a height of at least 1.5 m with full walls or walls with glazed windows;
- is equipped with other fixed structures or devices protecting the employee against falling from heights (eg. permanent, barriered platforms).

In accordance with the Work Regulations for Employees of ORLEN SA, works at heights are considered as particularly dangerous. They can be taken and performed only if at the same time:

- a) at least minimum requirements resulting from state regulations in the scope of performed works;
- b) requirements included in a written permit for their implementation;
- c) requirements contained in the work implementation instruction based on written permits;
- d) arrangements contained in BIOZ (Health and Safety Plan) or IBWR (Instruction for safe execution of works) approved by an authorized representative of ORLEN SA

are met.

Works at heights should be performed on the basis of the required documentation (including IBWR (Instruction for safe execution of works), developed taking into account the JSA applications, with caution and using permanent supervision (in accordance with the currently valid internal organizational act on the implementation of work based on written permits in the Production Facility in Płock, Railway Terminal in Płock, Fuel Terminals and the PTA Facility in Włocławek) and strict abidance of the arrangements contained in this "Instruction".

Performing any work at heights by external entities is allowed only on the basis of a written one-off permit for performing particularly hazardous work or the "Instructions for safe work implementation" (IBRP) issued in accordance with the applicable separate internal organizational act in this matter. Employees of ORLEN SA performing work at heights are obliged to use valid instructions at the workplace.

Work at heights can only be performed by people who have valid required OHS training and medical examinations without contraindications to perform such work, while work at high altitudes can be performed only by people possessing the required certificates confirming their competence to perform works with rope access.

Work at heights can not be performed by: juvenile employees, trainees, apprentices. In addition, work at high altitudes can not be performed by breast-feeding woman.

All works at heights should be properly planned, organized, maintained and supervised.

Before commencing work, the external contractor is required to specify:

- risk of falling of people or objects,
- selection of appropriate and effective methods for risk reduction and control as well as appropriate equipment,
- the possibility of adverse weather or other external factors,
- selection of appropriate and permanent anchoring points for the equipment,
- free fall path, including the following components: length of the safety cable + length of the expanded shock absorber + the height at which the employee is located + the safety margin.
- carry out a last-minute risk analysis (LMRA):
 - ✓ Do you know the hazards resulting from the work performed?
 - ✓ Are the equipment, tools, machines and devices that you're using in the required technical condition?
 - ✓ Are you careful and avoiding routine?
 - ✓ Is there order and tidiness in the workplace?

	SAFETY STANDARDS	ORLEN S.A.
Version: January 2024	OCCUPATIONAL HEALTH AND SAFETY EXECUTIVE GUIDELINES FOR CONTRACTORS	Page no.: 25

- ✓ Do you have all the required personal protective equipment, the required tools?

Before commencement of work the Contractor is required to:

- check the qualifications, medical examination and training of employees,
- introduce employees with the job safety analysis (JSA), IBWR (if required), one-off permit,
- carry out last-minute risk analysis (LMRA),
- at the workplace, discuss with employees selection and completion of personal protective equipment against falling from heights and select or make anchoring points for PPE against falling from heights,
- communicate to employees the methods of evacuation and secure the means necessary for this purpose, i.e. an evacuation set selected for work at heights,
- provide adequate measures to prevent fall from heights when evacuating people,
- designate and mark in a permanent way a danger zone in which there is a risk of tools and materials falling from heights,
- remove persons not related to the work from the work area,
- inspect technical research of devices used for work at heights (work platforms or aerial platforms),
- check the conformity of the scaffolding assembly with the technical and operational documentation or assembly instructions,
- fence the work area with a permanent fencing.

The Contractor is obliged to:

- use properly selected and tested measures to prevent falls from heights - remember about documents confirming their efficiency,
- perform, on a daily basis, a visual inspection of the technical condition of the protective balustrades and other protective devices, as well as check the technical condition of anchoring points,
- protect tools / components from falling from a height,
- when moving, always hold the handrail - do not keep your hands in your pocket or dangerous, loose objects that may fall out,
- when entering a higher level, remember to close the access door / hatch,
- always be sure that the scaffolding has been approved for work, is properly positioned, constructed and secured by a handrail.

After the completion of work the Contractor is required to:

- clean up all tools and materials or, in justified cases, secure them in an effective manner against the possibility of falling from a height and permanently enclose the danger zone,
- all vertical communication routes should be secured against the possible of entering by bystanders,
- confirm in writing the fact of completion of work at heights in the permit,

In an emergency situation Contractor is obliged to:

- follow the emergency scenario described in the IBWR / BIOZ / IBRP / permit (information about nearest evacuation assembly point, proper evacuation equipment),

 ORLEN	SAFETY STANDARDS	ORLEN S.A.
Version: January 2024	OCCUPATIONAL HEALTH AND SAFETY EXECUTIVE GUIDELINES FOR CONTRACTORS	Page no.: 26

- employees performing work at heights should evacuate or be evacuated to ground level as soon as possible,
- evacuation at heights is performed by the workers adequately trained for duties resulting from the assurance of work at height / belayers, that are nearby,
- use the prepared evacuation kit or other equipment specified in IBWR / BIOZ / IBRP / written permits.

11. Regulation on conducting earthworks in the ORLEN S.A.

1. Earthworks are works in excavations below the depth of 0.5m from the ground level.
Control ditch - a ditch made by hand, without the use of mechanized equipment, with a ground breach below 0.5 m, enabling precise determination of the actual location of the technical infrastructure network (location and depth of cable routes). It is assumed that control ditches should be carried out along the indicated cable routes at the collision points indicated by the authority issuing the consent to the derogation, resulting from the geodetic obstacles sketches.
2. Earthworks should be carried out based on the approved detailed design and construction design, as well as based on geodetic staking out with prepared sketches of obstacles for "closed area" or a current map for illustrative purposes for other areas.
3. For each excavation with a depth of more than 4.0 m, a draft of the excavation should be prepared, specifying the method of its protection, its parameters (eg course, slope inclination) and the organization of works inside it and the access / evacuation routes.
4. The basic document in the scope of health and safety, necessary to start and carry out works in trenches, excavations, ditches, is the Instruction for safe execution of works (IBWR) for a specific task, prepared by the Contractor's Works Manager. The document should be prepared taking into account the JSA (Job Safety Analysis) conclusions.
5. On the premises of ORLEN SA. all earthworks must be carried out on the basis of written one-off permits for performing particularly hazardous works.
6. In cases specified by ORLEN S.A. earthworks are allowed to be carried out on the basis of the Instructions for safe work implementation (IBRP).
7. Conducting earthworks near the main power and fiber-optic cable routes at the Production Facility in Płock requires the terms of their conduct to be agreed with the CHP Plant, on the premises of the CCGT Włocławek Facility with the Power Plant Operation Engineer on duty and a specialist in the electrical industry, and in the case of Fuel Terminals located outside the Production Plant in Płock, in agreement with the facility manager.
8. Conducting earthworks on the premises of the Production Plant in Płock with the use of mechanized equipment in the vicinity of electric power and teletechnical and fiber-optic main cable routes is possible only after obtaining individual deviations from authorized persons in writing.
9. Dangerous places should be permanently fenced (warning tape is not allowed to be used to protect earthworks) and marked with warning boards, and after dark or at night, the excavations should be covered and permanent red warning light should be used.
10. All depressions in the field, i.e. excavations, pits, ditches, etc., should be secured with protective barriers (1.1 m high) and curb boards (0.15 m high), set at a distance of no less than 1 m from the edge of the cavity.
11. Trench walls deeper than 1 m should be effectively protected against landslides.

	SAFETY STANDARDS	ORLEN S.A.
Version: January 2024	OCCUPATIONAL HEALTH AND SAFETY EXECUTIVE GUIDELINES FOR CONTRACTORS	Page no.: 27

12. The walls of wide-open excavations (with a bottom width of more than 1.5 m) should be secured taking into account JSA, e.g. by means of sloping, where the inclination of the slope depends on the depth of the excavation and the soil category.
13. Securing the walls of the excavation deeper than 4 m should be performed in accordance with a specially developed design documentation.
14. When making excavations with slopes with a safe gradient, it is necessary to:
 - secure, in the strip of land adjacent to the upper edge of the slope, gradients enabling easy outflow of rainwater, with a width equal to three times the depth of the trench,
 - eliminate the violation of the soil structure of the slope on an ongoing basis by removing the disturbed soil, while maintaining safe gradients of the slope at all its points,
 - monitor the condition of the slope after rain, frost and a longer break in work.
15. The contractor should ensure safe access routes to the interior of the excavation, ensuring access to the work sites. It is allowed to communicate inside the excavation by means of stairs and ramps (shallow excavations), stairs and stably attached ladders and communication routes from scaffolding.
16. Excavations with a depth of more than 1 m should be equipped with safe descents using stairs with a minimum width of 1.2 m or certified ladders, and the distance between descents should not exceed 20 m.
17. For the conducted earthworks, the Contractor must provide adequate personal protection equipment (PPE) and collective protection measures.
18. Vehicles and construction machines can not be located closer than 3m. from the excavation if their work is not related to this excavation.
19. The movement of all means of transport next to the excavations should take place outside the boundary of the natural wedge of the ground, not closer than 1 m.

Before starting work, you must check:

- **the concentration of gases / vapors that may form explosive mixtures with air (below 10% of the lower explosive limit),**
- **oxygen content (above 20% and below 22.5%),**
- **the concentration of toxic substances - for benzene, butadiene it's 0 ppm, and for other identified toxic substances it is below the threshold limit value (TLV) expressed in mg/m³.**

The parameters above entitle you to start the work.

Requirements after completing earthworks:

- secure tools and equipment,
- tidy up the workplace,
- report changes to the underground infrastructure in the form of an as-built geodetic inventory and provide this information to the Geodetic and Cartographic Documentation Team in relation to closed areas of Orlen S.A. or to the locally appropriate Center for Geodetic and Cartographic Documentation in relation to other areas of Orlen S.A. Failure to carry out the as-built geodetic inventory eliminates the possibility of accepting the works and constitutes a serious violation of the basic obligations of the Contractor.

	SAFETY STANDARDS	ORLEN S.A.
Version: January 2024	OCCUPATIONAL HEALTH AND SAFETY EXECUTIVE GUIDELINES FOR CONTRACTORS	Page no.: 28

12. Regulation regarding works inside tanks, closed apparatus and in drains at the ORLEN S.A.

Work inside tanks and confined spaces - activities requiring entry into the interior of all types of tanks, reservoirs, containers, silos, bunkers, gasmeters, gauges, scrubbers, reactors, columns, evaporators, vats, dryers, boilers, furnace chambers, pipelines, cisterns and other analogous devices.

In accordance with the Work Regulations for Employees of ORLEN SA works inside tanks and apparatuses as well as works in drains are classified as particularly dangerous works.

Entering tanks and sewage manholes and performing any works inside them is allowed only on the basis of:

- written one-off permit for performing particularly dangerous work or Instructions for safe work implementation of particularly dangerous works and "Camera entry cards" (Annex no. 18)
- in addition, in case of using power tools - a written order to perform the work in accordance with the currently valid "Instruction for the organization of safe work on devices, installations and power grids at the ORLEN SA".

Work inside tanks and in drains may only be performed by persons who have valid required OHS training and medical examinations without contraindications to perform such work. They cannot be performed by: young workers, trainees, apprentices and breast-feeding woman. An inspector of an external institution as a one-man Contractor is exempt from the need to have a valid certificate of completion of the periodic OHS training for persons managing employees and to have the appropriate authorization to collect permits.

Work inside tanks and in drains must be supervised and coordinated by a designated employee, at least with the qualifications of the person managing the employees and must be able to quickly and safely evacuate employees.

The Contractor is responsible for:

- providing the Supervisor with a list of employees of the executive team,
- completing the "Contractor's preparation survey for work",
- strict adherence to rules, regulations and safe working methods,
- full use of efficient safety measures specified in the permit,
- equipping subordinate employees with anti-electrostatic clothes and antistatic shoes as well as other appropriate and efficient personal protective equipment,
- equipping employees conducting work in confined spaces (within the meaning of *paragraph 85 of the Regulation of the Minister of Labor and Social Policy of September 26, 1997 on general health and safety regulations*) in:
 - individual detectors, which should provide protection against occurring threats, in places requiring the use of such detectors. Contractor's employees entering confined space must have personal multi-gas detectors, which should be used and calibrated depending on the given location:
 - at the Production Facility in Płock: personal multi-gas detector for **O₂**, **HC**. The remaining toxic gas, i.e. **H₂S**, depending on the possibility of occurrence in a given installation;
 - at the PTA Facility and the CCGT Włocławek Facility: personal multi-gas detector for **O₂**, **HC**. The remaining toxic gas, i.e. **CO**, depending on the possibility of occurrence in a given installation.
 - ORLEN SA will enable Contractors the access to the detector rental located on the premises of the Production Plant, operated by a company from the Capital Group - ORLEN EKO Sp. z o.o.,
 - After signing the Agreement, but no later than 45 days before the commencement of works requiring the use of detectors, the Contractor will determine the number of detectors needed to carry out work inside confined

	SAFETY STANDARDS	ORLEN S.A.
Version: January 2024	OCCUPATIONAL HEALTH AND SAFETY EXECUTIVE GUIDELINES FOR CONTRACTORS	Page no.: 29

spaces, during the works provided for in the scope of the contract, which, if used, will be forwarded to ORLEN EKO Sp. z o.o.,

- In the event of emergency work, ORLEN EKO Sp. z o.o. will secure the necessary number of detectors for the employees of Contractors,
- The ordered number of individual detectors will be available for the needs of the Contractor in the rental shop,
- The cost of renting the detectors referred to above is covered by the Contractor
- Contractor's employees may work with their own measuring devices, however they must meet the following requirements:
 - a valid calibration certificate issued by the manufacturer or manufacturer's authorized service,
 - the validity of the calibration certificate is set for 6 months, unless the device's user manual recommends more frequent calibration,
 - at the request of the representative of the Employer, the Contractor will each time provide the following detector documents, i.e. calibration certificate, CE declaration of conformity, operating manual with OHS instructions in Polish, as well as the functionality of automatic registration in the internal memory of measurement results and exceeding of alarm thresholds with the option of restoring records by the service,
 - detectors must be assigned to an employee working at a given moment in a confined space.
- complete respiratory protection equipment in a closed system, i.e. equipped with a compressed air cylinder. Respiratory protective equipment used to work in confined spaces should be functional, have the required certificates and be used in accordance with the manufacturer's instructions. If the diameter of the manhole or the technological opening allows for free entry and safe evacuation, the worker / lifeguard may enter the tank in respiratory protection equipment, i.e. wearable breathing apparatus with a composite cylinder, while the air supply should allow work for a minimum of 30 minutes for heavy works. If the diameter of the manhole or technological opening and the internal structure of the tank, device or technological apparatus do not allow for free entry and safe evacuation in a wearable breathing apparatus with a cylinder - the worker /lifeguard should enter the tank using a compressed air line breathing apparatus with an escape kit, with an air cylinder with a supply of compressed air (e.g. Air Pas Colt or UWS, or similar technical solutions).

Note! Under no circumstances should masks with gas filters be used in the tank.

- providing employees with instruction on the working conditions given in the permit and safe working methods, as well as on neighboring devices or installations posing a threat; supervision over the safe performance of work by subordinate employees,
- immediate discontinuation of work, if you receive a notification or notice on emergency condition that poses a threat, or use of dangerous methods of work,
- participating in the workplace control after the completion of works carried out by the Operational Supervisor or Belayer,
- proper closure of the permit with the time of completion of the work, immediately after its completion.

When preparing the tank for people entry, the Contractor is responsible for:

- emptying the tank of media,
- purging the tank with inert gas (if technically possible),
- cutting off and blinding inflows and outflows,

	SAFETY STANDARDS	ORLEN S.A.
Version: January 2024	OCCUPATIONAL HEALTH AND SAFETY EXECUTIVE GUIDELINES FOR CONTRACTORS	Page no.: 30

- All pipes supplying and discharging media to the tank, including vents and breathing pipes, if they do not lead directly to the atmosphere, should be cut off with closing valves and plugged with plugs in accordance with the currently applicable internal act regarding recording of setting up and removal of plugs at the premises of ORLEN S.A.,
- If the plug protecting the workplace against the appearance of hazardous energy is covered by the LOTO system, the lock is placed on the plug in accordance with the detailed LOTO instruction for a given Department/ Installation,
- The plugs should have the appropriate diameter, thickness and be made of a material resistant to pressure, temperature and corrosive effects of media on the active side, and should have an "eyepiece" or "eyelet" - a round end protruding above the connector,
- Disconnection by means of closing valves (valves, taps or gate valves), even in a double arrangement, is insufficient and not allowed,
- if the design of the connections does not allow for the disassembly of pipes or fittings (welded connections), a double closure with an open vent between them is allowed,
- This vent must be directed directly to the atmosphere and the vent valve must be secured in the open position. In this case, the closed main valves should also be secured against changing their position. It is absolutely necessary to check whether the open venting connection is unobstructed. Double closure with valves with open vent is covered by the LOTO system.
- bringing the interior of the tank to the temperature of $\pm 5^{\circ}\text{C}$ from the ambient temperature - if it is possible due to technical and technological means, in other cases ensure that work is carried out safely,
- analyze the atmosphere inside the tank,
- do not use oxygen to ventilate the tank,
- mark work places.

After emptying the tank of hazardous media and preparing it for the entry of people, analyzes of the interior atmosphere for oxygen content, explosive concentrations and toxic concentrations should be performed. The analysis should be made no earlier than 30 minutes before entering for the first time, using a calibrated measuring instrument. Subsequent analyzes should be performed in accordance with the frequency specified in the written permit and immediately before each time people enter the tank (current calibration and inspection documentation available for inspection by the owner of the measuring device).

Before starting work, it is mandatory to check:

- **concentration of gases/ vapors that may form explosive mixtures with air (below 10% of the Lower flammability limit),**
- **oxygen content (above 20% and below 22.5%),**
- **the concentration of toxic substances for benzene, butadiene, ethylene oxide, mineral oils and phenol is 0 ppm, and for other identified toxic substances it is below the highest permissible concentration (TLV) expressed in mg / m³ and, respectively, in ppm.**

Compliance with the parameters above entitle you to start the work.

Toxicity measurement must be carried out in accordance with the instrument's instruction manual (measurement time depends on the parameters of the instrument, pump efficiency - if the instrument is equipped with a pump, sensitivity of sensors/ detectors to a given gas, and thus the exposure).

 ORLEN	SAFETY STANDARDS	ORLEN S.A.
Version: January 2024	OCCUPATIONAL HEALTH AND SAFETY EXECUTIVE GUIDELINES FOR CONTRACTORS	Page no.: 31

Measuring instruments (toxicometers) should be set in accordance with the accepted alarm thresholds. If benzene, butadiene, ethylene oxide, mineral oils and phenol are present in the atmosphere of the tested tank, closed apparatus, or confined space, the toxicity for these substances should be equal to 0ppm.

A tabular summary of toxic substances:

Toxic substance	NDS [mg/m ³]	NDS [ppm]	Acceptable indication on the meter ≤ [ppm]	The sensor in the meter
Benzene	1,6	0,5	0	PID Lamp 10,6eV
Butadiene	2,2	1,0	0	
Ethylene oxide	1,0	0,5	0	
Mineral oils	5,0	0,5	0	
Phenol	7,8	2,0	0	
Hexane – representative of other organic compounds (lowest alarm threshold)	72,0	20,1	4	
Hydrogen sulfide	7,0	4,9	4	Intended for H ₂ S
Carbon monoxide	23,0	19,7	18	Intended for CO
Ammonia	14,0	19,8	14	Intended for NH ₃

Accepted alarm thresholds in the meters:

- Production Facility in Płock/PTA Włocławek (for PID lamp with 10,6eV power) - set (no more than): low alarm to 4 ppm, high alarm to 5 ppm,
- Production Facility in Płock for hydrogen sulphide (for H₂S sensor) – set (not more than): low alarm to 4 ppm, high alarm to 5 ppm,
- Production Facility in Płock /PTA Włocławek for carbon monoxide (for CO sensor) – set (not more than): low alarm to 18 ppm, high alarm to 20 ppm,
- PTA Włocławek for ammonia (for NH₃ sensor) - set (not more than): low alarm to 14 ppm, high alarm to 20 ppm.

If the analytical control is performed by authorized employees of the Contractor (an external company operating on the basis of a relevant provision in the Agreement with ORLEN S.A.) using its own measuring device, the measurement should be performed under the direct supervision of the facility staff, with measuring devices set in accordance with the accepted alarm thresholds in ORLEN S.A.

Before starting work in manholes and similar devices, it is necessary to: deactivate a given section of the sewage system by plugging all connections to this section, empty and ventilate sections where work is to be performed, analyze the interior atmosphere for oxygen content, explosive concentrations and toxic concentrations.

The analysis should be performed no earlier than **30 minutes** before each entry.

The results of the analyzes should be entered into the permit for performing particularly hazardous works and the "Camera entry card" or attached in writing to the IBRP. In order to validate a permit issued in the electronic system, the analysis remains valid for 60 minutes. This is without prejudice to the obligation set out in section 2 regarding the performance of the analysis before each entry into the manhole.

	SAFETY STANDARDS	ORLEN S.A.
Version: January 2024	OCCUPATIONAL HEALTH AND SAFETY EXECUTIVE GUIDELINES FOR CONTRACTORS	Page no.: 32

Samples for analysis should be collected in a way that does not require the worker to enter the sewage chamber.

Entrance to the sewage chamber may be allowed when the results of analyzes confirm the absence of an explosive and toxic hazard, and the oxygen content is not less than 20% by volume. and not more than 22.5%. No risk of explosion means a concentration lower than 10% of the Lower Explosion Limit (LEL). No toxic hazard means the concentration of benzene, butadiene, ethylene oxide, mineral oils and phenol equal to 0ppm and for other toxic substances below the maximum permissible concentrations (NDS).

- If the methods used do not ensure a safe internal atmosphere, e.g. in the presence of sludge, etc. creating the possibility of releasing hazardous media in the course of work, it is necessary to:
 - use continuous ventilation with such an air exchange per hour as to prevent the occurrence of explosive and toxic concentrations,
 - continuously monitor the occurrence of explosive and toxic concentrations.
- Work in sewage chambers should be carried out with care and with all precautions. They should be performed in respiratory protective equipment and in a safety harness with a lifeline attached. The worker should be equipped with a detector measuring the explosive concentration.
- Work in sewer manholes may be performed by only one worker who is secured outside by two other persons who maintain constant eye contact with him. In exceptional cases, the work of two employees is allowed, if the construction conditions of the manhole allow it.

Works in teletechnical wells, in power cable ducts, in measuring chambers on water networks and in chambers with fittings on water networks can be performed without respiratory protection equipment, if analytical measurements do not show explosive concentrations and the presence of toxic substances, and the oxygen content is within 20÷22.5%. In this case, a safety harness with a lifeline attached should be used, and the analytical control should be repeated at least every 30 minutes. The worker must be equipped with a personal multi-gas detector or detectors capable of measuring oxygen content, explosive concentration and toxic concentration.

During works requiring the opening of sewage chambers, taking into account the possibility of an explosive mixture escaping outside, it is necessary to:

- issue a permit for particularly hazardous work - work in sewer manholes and perform explosiveness and toxicity measurements,
- indicate in the permit the planned well to be opened (e.g. sewage/rainwater pumping place, etc.),
- immediately before the opening of the well, measure the explosiveness around the planned well to be opened and continue the work if the explosiveness is found to be below 10% LEL;
- after opening the well, check the explosiveness, if the explosiveness exceeds 10% LEL, stop, close and secure the well; re-open the well only after eliminating potential sources of ignition within a radius of 20 m (e.g. de-energize ordinary, non-explosion-proof electrical devices; remove elements accumulating electrostatic charges, etc.),
- fencing off the area within a radius of 20 m from the open sewage well, temporarily marking the fenced area as an explosion hazard zone (warning sign - yellow Ex triangle),

	SAFETY STANDARDS	ORLEN S.A.
Version: January 2024	OCCUPATIONAL HEALTH AND SAFETY EXECUTIVE GUIDELINES FOR CONTRACTORS	Page no.: 33

- within a radius of 20 m from an open sewage well, stop works with the use of open fire or carry them out with the use of continuous control of explosive concentrations below 10% LEL,
- within a radius of 20 m from open sewage system wells, eliminate potential sources of ignition, (e.g. de-energize ordinary, non-explosion-proof electrical devices; remove electrostatic charging elements, stop vehicle traffic, etc.), fence off the area (within 20 m) and temporarily mark the fenced area as potentially explosive (yellow Ex triangle). Conduct continuous analysis of explosiveness in the open well until it is closed. If the potential source of ignition cannot be eliminated, if the explosiveness in the well increases above 10% LEL, stop work, close and secure the well,
- drain sewage/rainwater into the sewage system with a hose without a connector (e.g. a cut off end) to avoid hitting the connector against the chamber wall during turbulent flow.

When supervising the work, Contractor is obliged to:

- enter the tank first to check and confirm its preparation for the work - safeguards specified in the permit are applicable,
- react immediately after noticing that employees are working dangerously,
- prevent the use of dangerous practices by employees,
- familiarize employees with the permit, current threads and ways to avoid them,
- ensure carrying out the required analysis and control measurements,
- do not start work without making sure that the tank is properly prepared for people to enter - the principle of limited trust applies,
- use proper methods to avoid an accident,
- organize work in compliance with safety requirements,
- carry out emergency instructions every time before starting work, including safety analysis at the workplace or during specific activities - LMRA (Last Minute Risk Analysis)
- observe the work carried out in a systematic manner.

During belaying and rescue operations the contractor is responsible for:

- control of compliance with the permit conditions,
- performing visual inspection of the work site and ensuring its safe implementation,
- immediate discontinuation of works, in case of finding out or receiving informations about the emergence of dangerous states, reducing the degree of safe performance of work specified in the permit or gross violation of applicable provisions and principles of OHS and fire protection,
- using respiratory protection equipment and safety harness, and the use of other necessary safeguards so as not to lead to potential accident hazards while providing assistance.

It is assumed, as a rule, that for two and more workers inside the tank, two Belayers permanently located at the hatch of the tank should be designated. The third Belayer can operate the equipment supplying fresh air or do other work nearby (no more than 15m), so that he can be in sight and hearing range at any time and could - in the event of evacuation of all employees from inside the tank - inform emergency services.

	SAFETY STANDARDS	ORLEN S.A.
Version: January 2024	OCCUPATIONAL HEALTH AND SAFETY EXECUTIVE GUIDELINES FOR CONTRACTORS	Page no.: 34

The Contractor is obliged to:

- prevented accidents before, during and after work,
- ensure the possibility of efficient evacuation of people,
- personally supervise particularly dangerous works,
- reinforce employees' awareness of the main threats and precautions
- immediately report an accident or a threat to the OHS services and the Company Fire Brigade.

The Employee should not:

- enter the tank freely,
- start the work without getting acquainted with the written permission, entry card and appropriate instructions,
- start work without health and safety instructions given by his supervisor,
- enter the tank before making sure that the control tests / analysis have been carried out and checking their results,
- conduct work without belaying from other people,
- put a cylinder with technical gases in the tank,
- light a gas burner inside the tank,
- use masks with absorbers (filtering equipment) while working in the tank'
- use transformer welders in tanks.

The Employee is obliged to:

- use appropriate personal protective equipment (clothing with anti-electrostatic and flame retardant properties, antistatic protective footwear and face and eyes shields with CE marking and protective helmet with 4-point fastening).
- avoid errors, risks and prevent threats at their sources,
- not to use masks with absorbers (filtering equipment) when working inside tanks,
- not to use transformer welders inside tanks
- use EX electric tools and non-sparking wrenches,
- use safe lighting in the EX version,
- reprimand others when they are working dangerously,
- watch out for sparks generated during welding or grinding to not to damage personal protective equipment (braces, cords),
- inform your supervisor if you see:
 - ✓ signs of indisposition for yourself or another employee,
 - ✓ symptoms or an emergency situations, regardless of their size (eg. fire, leakage, etc.).

13. Regulation on detailed rules for determining qualifications of persons dealing with the exploitation of equipment, installations and electrical networks at the ORLEN S.A.

Persons involved in the exploitation of equipment, installations and electrical networks are required to have proper qualifications confirmed by a certificate issued by the Qualification Committee appointed by the President of the Energy Regulatory Office.

Confirmation of having qualifications in the scope of exploiting equipment and installations is not required for users exploiting:

- electrical equipment with a voltage of no more than 1 kV and a nominal power not higher than 20 kW, if the device's documentation specifies its operation,
- thermal equipment or installations with installed power not higher than 50 kW.

	SAFETY STANDARDS	ORLEN S.A.
Version: January 2024	OCCUPATIONAL HEALTH AND SAFETY EXECUTIVE GUIDELINES FOR CONTRACTORS	Page no.: 35

From 30.10.2011, valid for this day "Certificates confirming qualifications in the field of equipment, installations or networks" issued by qualification commissions under existing provisions become indefinite certificates, excluding professional qualifications of persons engaged in the exploitation of equipment, installations or networks and providing services to consumers, micro, small and medium-sized enterprises, which remain valid until the expiry of the period for which they were issued.

The verification of compliance with the qualification requirements is repeated every 5 years in the case of persons involved in the exploitation of networks, devices or installations listed in Annex 1 to the Principles providing services to consumers within the meaning of the Act of 23 April 1964 - Civil Code (JoL 2020, item 1740) and micro, small and medium-sized entrepreneurs, within the meaning of the Act on the freedom of economic activity.

Having a qualification certificate entitling to perform work in a supervisory position does not authorize to perform work in the operating position and vice versa.

The person performing activities in the field of operation or supervision must carry the original certificate of qualification during work and show it to the authorized employees of the client.

14. Operational regulation regarding the protection of nitrogen and air pipelines against their contamination with dangerous media at the Production Facility in Płock.

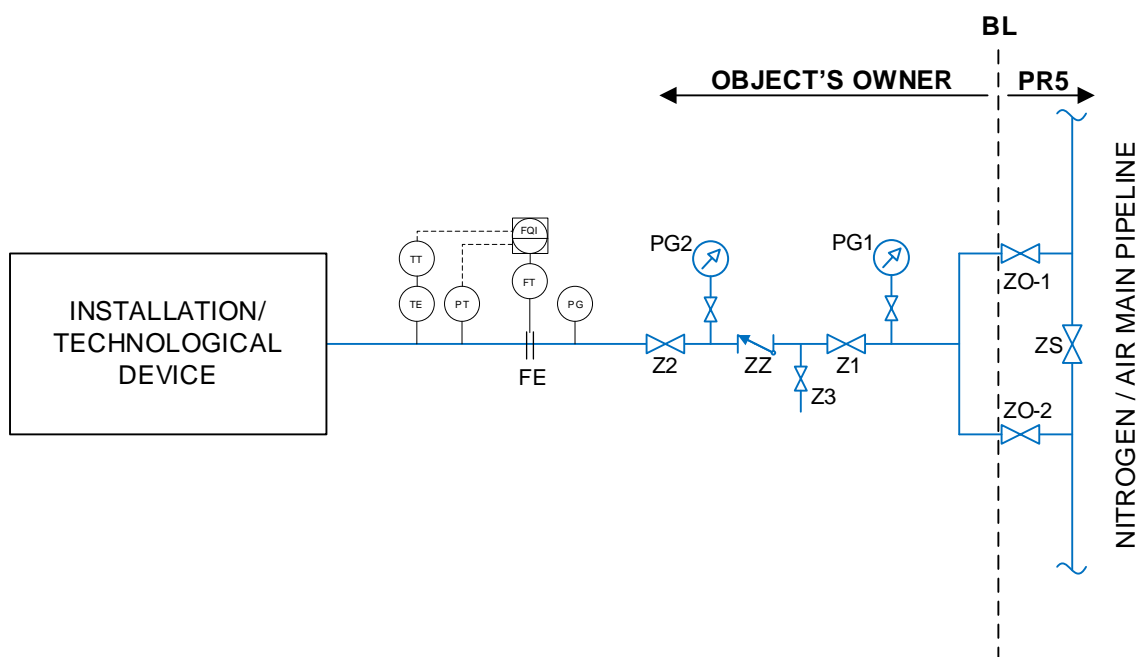

Marking:

- Z** – shut-off fittings
- ZZ** – check valve
- ZS** – section shut-off fittings
- ZO** – main shut-off fittings
- PG** – manometer
- FE** – flange (example of the measuring system based on the pressure difference)
- BL** – Battery Limit

Fig. 1

 ORLEN	SAFETY STANDARDS	ORLEN S.A.
Version: January 2024	OCCUPATIONAL HEALTH AND SAFETY EXECUTIVE GUIDELINES FOR CONTRACTORS	Page no.: 36

The above diagram does not take into account the place of installation of the eyepiece plug, the location of which is within the control of the owner of the installation / technological device

Installations and technical equipment supplied with nitrogen or air should be connected to the main pipelines in a way that will prevent contamination of main pipelines with hazardous media, and their connection with main pipelines must be made in accordance with Figure 1.

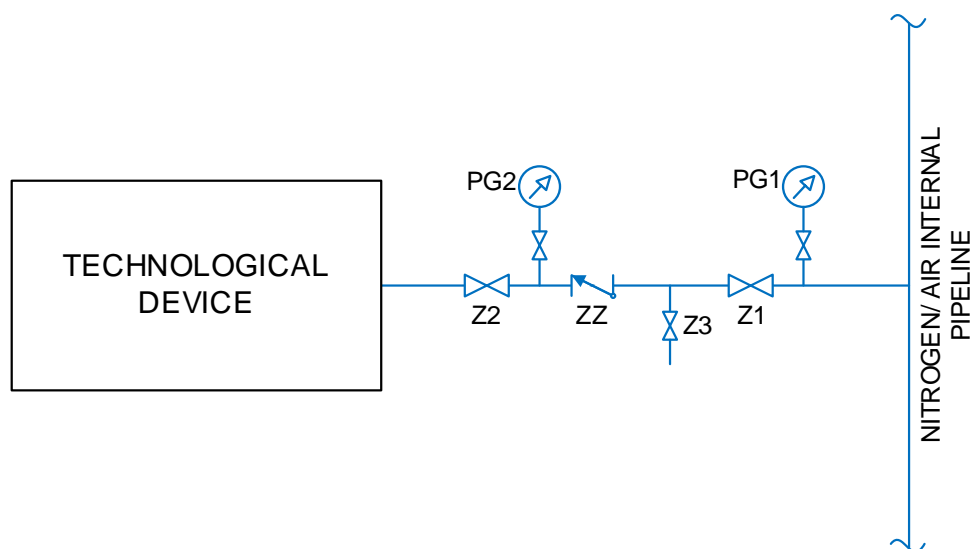

Marking:

- Z** – shut-off fittings
- ZZ** – check valve
- PG** – manometer

Fig. 2

The above diagram does not take into account the place of installation of the eyepiece plug, the location of which should be taken into account by the owner of the technological device.

For continuous supply of technological devices with nitrogen or air, their connection to internal nitrogen or air pipelines must be made in accordance with Figure 2.

	SAFETY STANDARDS	ORLEN S.A.
Version: January 2024	OCCUPATIONAL HEALTH AND SAFETY EXECUTIVE GUIDELINES FOR CONTRACTORS	Page no.: 37

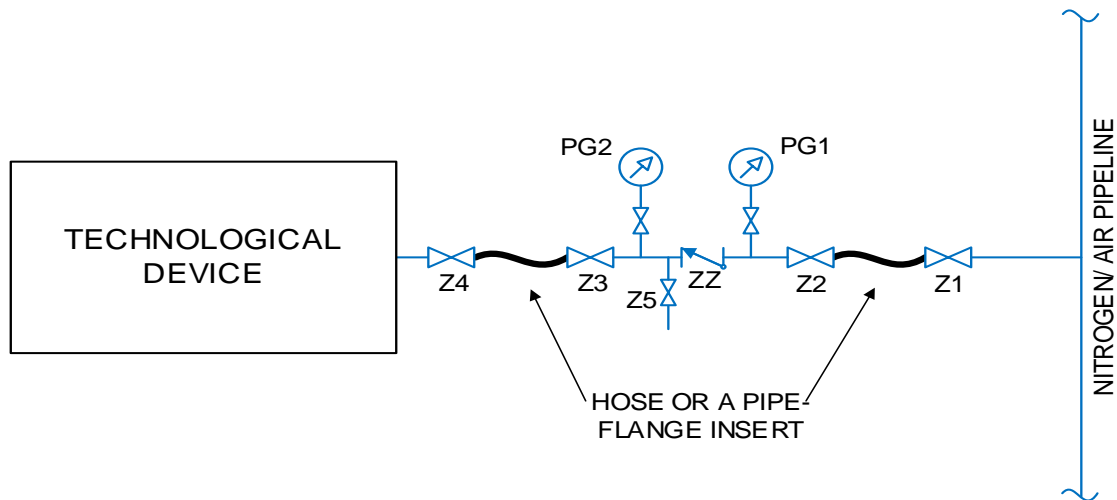

Marking:

- Z** – shut-off fittings
- ZZ** – check valve
- PG** – manometer

Fig. 3

The pipe insert or hose should only be installed while the nitrogen or air is being drawn in, and removed immediately after the operation is completed

When periodically supplying technological devices with nitrogen or air, connection with nitrogen or air piping must be carried out in accordance with Figure 3.

Colors of hoses used to connect energy media on the premises of ORLEN:.

- white or black with white elements, e.g. stripes for nitrogen;
- blue or black with blue elements, e.g. stripes for air or water;
- red or black with red elements, e.g. stripes for steam;
- colors other than the above-mentioned for media not included in this ordinance i.e. acid, lye, etc.

It is forbidden to arbitrarily connect hoses and other connections to the main nitrogen and air pipelines without consulting the Gas Management Complex (PR5) and without applying an appropriate security system.



Fig. 4

Fittings and pipelines supplying nitrogen and air to technological equipment should be described and marked in accordance with the rules in force at the Production Facility in Płock.

	<p style="text-align: center;">SAFETY STANDARDS</p>	<p style="text-align: center;">ORLEN S.A.</p>
<p>Version: January 2024</p>	<p style="text-align: center;">OCCUPATIONAL HEALTH AND SAFETY EXECUTIVE GUIDELINES FOR CONTRACTORS</p>	<p style="text-align: center;">Page no.: 38</p>

Nitrogen ignition switch should be equipped with technical solutions that make it impossible to connect a flexible hose to a medium other than nitrogen to the ignition switch.

15. Regulation regarding the recording of setting up and removal of plugs at the premises of ORLEN S.A.

The most effective way to cut off the medium is to install a suitable plug on the flange connection. Apparatuses, devices and pipelines containing the following media: flammable, corrosive, irritating, toxic, technical gases, hot water, steam and other hot media should be absolutely blinded for technological, renovation, investment purposes, etc. In the case of a plug protecting the workplace against the appearance of hazardous energy, it is covered by the LOTO system. The LOTO lock is placed on the end cap in accordance with the detailed LOTO instruction for a given Department / Installation. The plugs must be of appropriate diameter, thickness and made of a material capable of withstanding pressure, temperature and corrosive effects of media on the active side, and should have a "eyepiece" or "eye" - a round end protruding above the joint. After each assembly and / or disassembly of the plug, it is absolutely necessary to check the tightness of the flange connection.

The assembly and disassembly of each end cap should be recorded in the "Control Book for setting up and removing plugs",

The "Control Book for setting up and removing plugs" should be located:

- in control rooms, and in facilities without control rooms - in a place determined by the person managing the organizational unit responsible for the object,
- for building administrators that are exclusively offices and/ or social.

16. Regulation regarding introduction to the "Instructions for the control and operation of PiA interlock systems in the Production Facility of ORLEN SA in Płock and the PTA Facility in Włocławek".

The PiA blocking system is a significant security layer independent of the basic control system. The purpose of the blocking system is to reduce the risk of consequences of the threat for which it has been designed.

In case of exceeding the limit values of the process parameters, the blocking system executes automatically, without intervention of the operator, the activities that introduce the technological object into a safe state.

The locking systems are subject to strict design, operational and procedural requirements set out in the Regulation of the Comprehensive Prevention System No. 29/2015 / PT and the PN-EN61511 standard.

Service schedules for blocking systems are created based on the results of SIL safety integrity analysis. The SIL analysis relies on a qualitative and quantitative risk assessment of the operation of technological installations and takes into account the probability of occurrence of events and their consequences.

Changes in technological blocking systems, in particular regarding the implementation of blocking functions, set initiators and test intervals, may be made at the request of the person managing the Department / Block / Division, after approval by appropriate Fire and Technical Commissions. Activating the MOS switch (Maintenance Override Switch) disables the control of the given blocking parameter, therefore it should be used only in particularly justified cases limited to the necessary service needs. The duration of MOS in the active state should be as short as possible. The person managing the plant / block / department and, during his absence - the Production Process Foreman, is entitled to issue a permit to activate the MOS switch.

All cases of MOS activation and deactivation must be documented (justification, description of actions to limit the risk related to temporary blocking protection, registration of the exact activation / deactivation time) in the "Register of switching MOS switches".

	SAFETY STANDARDS	ORLEN S.A.
Version: January 2024	OCCUPATIONAL HEALTH AND SAFETY EXECUTIVE GUIDELINES FOR CONTRACTORS	Page no.: 39

POS switches (Process Override Switch) are used for bypassing these parameters, the fulfillment of which is not possible in specific phases of the installation's operation. Use of them should be limited only to such cases. All cases of activating and deactivating POS switches must be documented in the "Register of active MOS / POS switches" and in the "Production Process Foreman's Report Book".

17. Regulation regarding introduction to the "Rules of conduct in the field of telecommunication infrastructure on the premises of the Production Facility in Płock and PTA Facility in Włocławek".

Conducting works on the telecommunication infrastructure at the Production Facility in Płock, including the Fuel Terminal in Płock and the PTA Facility in Włocławek, requires absolute agreement on the scope, schedule and conditions for the implementation and collection of works and the issuance of documents proper for the implementation of these works. The obligation of arrangements also applies to the design documentation. Arrangements for infrastructure are carried out at the initiative of the person commissioning the project development or implementation of work with the person managing the ICT Network Team and in the case of a positive decision of the IT Department, the contracting authority obtains the consent for the proposed scope and schedule as well as the conditions for the implementation and acceptance of works. If the works carried out are related to the network transmitting signals about a fire or a chemical threat, the Chief Officer of the Company Fire Brigade should be additionally notified and confirmation of the completeness of the scope, schedule and conditions for the implementation and collection of these works should be obtain from him or from the person authorized by him. Conducting works on the telecommunication infrastructure of the electrical industry on the premises of the Production Facility in Płock and the PTA Facility in Włocławek, which includes:

- a. cable ducts, cable wells and a network of optical fiber cables between GPZ stations 1 and 2 and from the GPZ station to the GPR with accessories;
- b. direct fiber optic cables in the routes of MV power cables between GPR and OPR stations together with the equipment;
- c. teletechnical cable network for teletransmission in the NRB system together with the equipment;

requires compliance with the rules set out in a separate internal organizational act regarding the conduct of earthworks on the premises of the Production Facility in Płock and the PTA Facility in Włocławek. Each case of interference in the telecommunications infrastructure should be agreed with the Electricity Distribution Unit of the Heat and Power Plant. Conducting work on the telecommunication infrastructure of the automation industry on the premises of the Production Facility in Płock and the PTA Facility in Włocławek also requires arrangements with the authorized employee of the Software Development Team in the Automation Department and Production Support Engineer in the PiA industry responsible for the area, and for the scope of the Plant for Combined Heat and Power Plant or The Water and Sewage Plant appropriate persons in charge of this Departments should be notified. Conducting work on the telecommunications infrastructure of the mechanics industry on the premises of the Production Facility in Płock and the PTA Facility in Włocławek also requires making arrangements with an authorized employee of the Technical Office. Obtaining proper Consent means that as part of the activities it will be possible to perform works with the scope resulting from the agreement, whereby the basis for their implementation in addition to Consent is to have an approved proper written permit and other relevant permits resulting from the applicable in ORLEN SA. internal organizational acts regarding the implementation of works based on written permits in the Production Facility in Płock, Fuel Terminals and the PTA Facility in Włocławek as well as performing earthworks on the premises of the Production Facility in Płock and the PTA Facility in Włocławek.

 ORLEN	SAFETY STANDARDS	ORLEN S.A.
Version: January 2024	OCCUPATIONAL HEALTH AND SAFETY EXECUTIVE GUIDELINES FOR CONTRACTORS	Page no.: 40

Depending on the scope of the arrangements, the consent is issued:

- a. within the scope of arrangements for project documentation – in writing at a written request addressed to the IT Office,
- b. for work performance - in writing or by email on a written or e-mail application sent to the IT Office.

18. Regulation on the introduction to the official use of the Instruction of organization of safe work on electrical power equipment, installations and power grids in ORLEN S.A”.

Work on non-active electrical equipment should be organized in accordance with general health and safety regulations.

Works on active power devices can be performed:

- under voltage – i.e. work during which a person is in contact with live parts or with any part of his body, tools or other objects violates the under-voltage work zone;
- in the vicinity of voltage – i.e. work in the vicinity of unprotected electric power equipment or parts of it under voltage, during which a person is in the near-voltage work zone or any part of his body, tools or other objects violates this zone, and does not violate the zone work under voltage;
- when the voltage is off, i.e. work is performed with the voltage disconnected, with grounded power devices, during which the person with any part of his body, tools or other objects does not violate the work zone in the vicinity of voltage or other devices under voltage.

Rated voltage	Work zone under voltage D_L	Work zone in the vicinity of voltage D_V
kV	mm	mm
≤ 1	without touch	300
3	60	1120
6	90	1120
10	120	1150
30	320	1320
110	1000	2000
220	1600	3000
400	2500	4000

Tab. No. 1. Borders of work zone under voltage and work zones in the vicinity of voltage

 ORLEN	SAFETY STANDARDS	ORLEN S.A.
Version: January 2024	OCCUPATIONAL HEALTH AND SAFETY EXECUTIVE GUIDELINES FOR CONTRACTORS	Page no.: 41

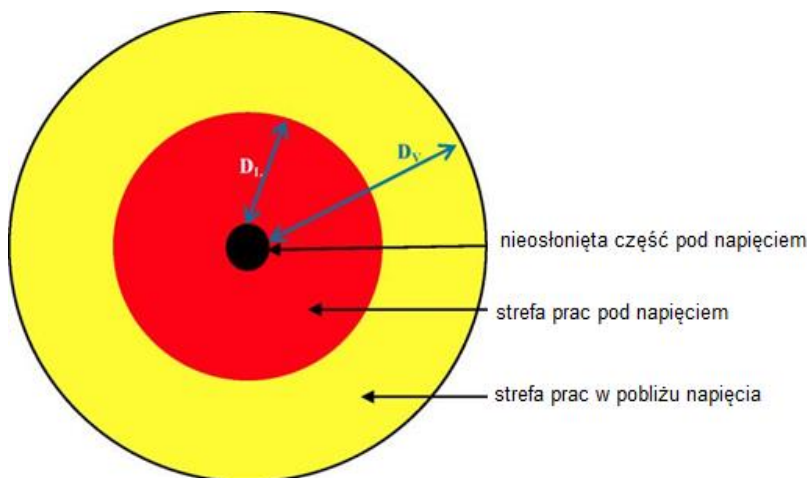

Fig. No. 1. Work zones

Basics of carrying out works:

Works on active devices, installations and power grids can be carried out on a written, verbal or non-command basis.

- Works performed without a command:
 - a) activities related to saving human health and life,
 - b) emergency operations to protect devices and installations from damage,
 - c) work performed by entitled and authorized employees involved in the operation specified in the workplace manuals - including work that creates the possibility of a particular threat to human health or life.

Persons performing actions and activities listed in points a) and b) depending on the situation, should take measures necessary for their own safety, and then inform the person responsible for conducting the electrical operations and the direct supervisor about the incident and circumstances justifying the action.

- Works on a verbal command
At a verbal command, all work for which no written order is required may be performed. A verbal instruction should be concise, unambiguous and repeated by the employee receiving the order.
- Works on a written order:
The following works must be carried out with a written order:
 - a) on devices, installations and power grids in conditions of a particular threat to human health and life,
 - b) for which a Supervisor is required,
 - c) for which the operator will deem it necessary.

Work in conditions of a particular threat to human health and life should be performed only on a written command and by a team of qualified employees.

For works performed on devices, installations and power grids in conditions of a particular threat to health and human life, the following works are included:

1. maintenance, modernization, renovation of power devices partially or completely energized, with the exception of work involving replacement of fuse links or light sources in circuits with a voltage up to 1kV with undamaged casing (the term "partially energized"

	SAFETY STANDARDS	ORLEN S.A.
Version: January 2024	OCCUPATIONAL HEALTH AND SAFETY EXECUTIVE GUIDELINES FOR CONTRACTORS	Page no.: 42

- electrical equipment (operating near voltage) is to be understood as equipment where only a part has been de-energized to perform the work; e.g. to carry out work on devices in a cubicle, field or pole station, the devices were turned off, but the jaws of the busbar or line disconnectors remained live,
2. performed near unshielded power equipment or parts of it under voltage,
 3. with power devices disconnected, but not grounded or grounded in such a way that no earthing (earthers) is visible from the workplace,
 4. when lowering and suspending wires on overhead power lines disconnected from electric voltage, in arches crossing railways, water and wheel roads,
 5. connected with identification and cutting of cables,
 6. when welding, soldering, replacing racks and single powercells and the entire battery bank,
 7. when the power line of a two-circuit overhead power line is disconnected from voltage, if the second track is under voltage,
 8. with power lines or overhead power lines under construction which cross in a zone limited by protective grounding with live lines or may be under voltage or with electric traction wires,
 9. during tests and measurements, excluding work:
 - 9.1 performed permanently by designated employees in specified workplaces (laboratories, test stations) or based on the workplace manual,
 - 9.2 where it is not required to interrupt the continuity of earthing, crossing barriers, removing covers (e.g. thermovision measurements)
 10. maintenance and repair of unloading devices for liquid and gas fuels, such as downpipes and unloading pumps with their installations,
 11. with disconnected, but not earthed, electrical power devices or their parts; in the work order, the orderer should make an entry **"with devices turned off without setting earthing devices"**,
 12. with radioisotope and high voltage neutralizers, used to neutralize electrostatic charges,
 13. with tanks, compressed air pipelines and compressors with working pressure equal to or greater than 50kPa - requiring disassembly of compressor elements, a section of pipeline or violation of supports and slings of pipelines,
 14. performed on the route of electric cable lines, if there is any doubt in the identification of the cable,
 15. carried out at the workplace where it is not possible to set earthing devices visible from the workplace; in this case, other effective means of protection against electric shock should be applied, which will ensure safe work performance,
 16. at power devices for which partial or total removal of earthing devices in the work place (eg for voltage tests) is necessary during work; in the work order, the client should make an entry: "with a partial - complete removal of earthing devices for trials",
 17. with overhead power lines disconnected from voltage that cross with live lines;
 18. construction of and operation on overhead power lines,
 19. operation on cable lines with remote power supply and on remote power supply devices,
 20. in cable wells, in rooms connected to them and in the fitter holes,
 21. when the electrostatic precipitator is disconnected from voltage, and it is necessary to enter inside the electrostatic precipitator chamber,
 22. fire hazardous in potentially explosive areas.

Before commencing work and preparing a workplace in conditions of particular danger, it is required to carry out training on work implementation by person: issuing a work order, coordinating the work, approving the work. The details of the training should be included in the workplace manuals.

	SAFETY STANDARDS	ORLEN S.A.
Version: January 2024	OCCUPATIONAL HEALTH AND SAFETY EXECUTIVE GUIDELINES FOR CONTRACTORS	Page no.: 43

Single-person work should be carried out by operating persons with qualifications in the operating position. A list of single-person works and the conditions for their execution should be included in the workplace manual.

Works that can be performed include:

- a) replacement of LV fuse links in control and signaling circuits - performed by the station's permanent services,
- b) visual inspection of LV, MV switchgears - by station services,
- c) visual inspection of the LV, MV, HV, UHV lines - from ground level,
- d) repair works in lighting and heating installations up to 1kV in electric stations, not requiring entering into the cells, removing barriers and shields, setting ladders,
- e) current maintenance of the battery bank, eg electrolyte density measurement, voltage measurement,
- f) maintenance works performed in the electric stations - if the required distances from unprotected live parts are maintained,
- g) mowing grass or removing snow from roads in LV, MV, HV, UHV stations,
- h) maintenance work on compressed air installations, with the exception of work requiring the dismantling of fittings or pipeline section or violation of supports and slings of pipelines with working pressure equal to or greater than 50 kPa,
- i) other works specified in the workplace manuals.

Formal and organizational requirements - written authorizations to perform the function:

1. Authorization for persons performing the functions of the Supervisor, Approver, Coordinator and Contractor of maintenance works is issued by the Operator or a person authorized by him.
2. At the Production Facility in Płock, on behalf of the Operator, written authorizations for persons performing functions of the:
 - a) Supervisor – is issued by a person managing the Electrical Maintenance Team,
 - b) Approver – is issued by the person managing the CHP Plant ,
 - c) Coordinator – is issued by the person managing the CHP Plant,
 - d) Contractor - is issued by a person managing the Electrical Maintenance Team.
3. At the PTA Facility in Włocławek on behalf of the Operator, written authorizations for persons performing functions of the:
 - a) Supervisor – are issued by the person managing the Terephthalic Acid Complex Maintenance Department,
 - b) Approver – are issued by the person managing the Terephthalic Acid Complex Maintenance Department,
 - c) Coordinator – are issued by the person managing the Terephthalic Acid Complex Maintenance Department,
 - d) Contractor – are issued by the person managing the Terephthalic Acid Complex Maintenance Department.
4. At the CCGT Facility in Włocławek written authorizations for persons performing functions of the:
 - a) Supervisor – are issued by the Director of the Włocławek CCGT Facility or a person authorized by him,
 - b) Approver – are issued by the Director of the Włocławek CCGT Facility or a person authorized by him,
 - c) Coordinator – are issued by the Director of the Włocławek CCGT Facility or a person authorized by him,
 - d) Contractor – are issued by the Director of the Włocławek CCGT Facility or a person authorized by him.
5. At the Fuel Terminals located outside the Production Facility in Płock, written authorizations for persons performing functions of the:
 - a) Supervisor – are issued by the person managing the Fuel Terminal or a person operating under an appropriate agreement,

 ORLEN	SAFETY STANDARDS	ORLEN S.A.
Version: January 2024	OCCUPATIONAL HEALTH AND SAFETY EXECUTIVE GUIDELINES FOR CONTRACTORS	Page no.: 44

- b) Approver – are issued by the person managing the Fuel Terminal or a person operating under an appropriate agreement,
 - c) Coordinator – are issued by the person managing the Fuel Terminal or a person operating under an appropriate agreement,
 - d) Contractor – are issued by the person managing the Fuel Terminal or a person operating under an appropriate agreement.
5. At ORLEN S.A.'s own petrol stations organization of work on devices, installations and power networks is regulated in a separate internal organizational act on the implementation of work with increased risk at ORLEN S.A.'s own fuel stations.
6. In technical facilities in other areas, written authorizations for persons performing functions of the:
- a) Supervisor – are issued by the person managing the facility,
 - b) Approver – are issued by the person managing the facility,
 - c) Coordinator – are issued by the person managing the facility,
 - d) Contractor – are issued by the person managing the facility.

Combining functions in the process of safe work organisation.

It is allowed to combine no more than two functions at the same time.

- a) The Supervisor may be a Coordinator; the Supervisor may be a member of a team of employees if he is not also a Coordinator and additionally holds a valid qualification certificate at the operating position.
- b) The Coordinator may act as the Supervisor or Approver if he additionally holds a valid qualification certificate at the operating position and a written authorization to perform the Approver function. **He can not be both the Supervisor and the Approver.**
- c) The Approver may be a member of a team of employees, if the order so provides. The decision about combining functions is made by the Supervisor. It is allowed to combine up to two functions.

19. The regulation for monitoring the technical condition of equipment in the ORLEN S.A.

1. The managers of investment projects (or executors of investment projects) are obliged to:
- a) Execution, after the construction of pipelines, "zero" measurements of wall thickness, in the amount consistent with pt. 9 of Instructions - for pipelines:
 - I, II and III hazard categories subject to UDT supervision (classification in accordance with Directive 2014/68/ EU),
 - transporting acetic acid, regardless of the parameters and diameter of the pipeline, in an amount such as for pipelines and hazard categories; and introduction of measurement results and other data to the electronic camera and pipeline management system - SZEOR.
 - b) Introduction of technical data to the SZEOR apparatus and pipeline management system for all devices covered by the Instruction built within the investment task.
 - c) Ensure, for the pipelines built on site (after assembling them), doing tests confirming the grade of material used - PMI (in accordance with point 9 item 5).
 - d) Provide to the Technical Infrastructure Department lists of devices with limited operating time and providing guidelines and material samples obtained from the equipment manufacturer, which are necessary to develop operational testing programs for these devices, in accordance with the principles described in paragraph. 8 of the Instructions.
 - e) Execute and transfer to Technical Infrastructure Department passports for equipment covered by the provisions of the Instruction.

	SAFETY STANDARDS	ORLEN S.A.
Version: January 2024	OCCUPATIONAL HEALTH AND SAFETY EXECUTIVE GUIDELINES FOR CONTRACTORS	Page no.: 45

2. Devices subject to UDT supervision.

Types of devices subject to UDT / TDT technical supervision are specified by the Regulation of the Council of Ministers of 7 December 2012 on the types of technical devices subject to technical supervision (Journal of Laws of 2012, item 1468).

2.2. The minimum scope of tests required by UDT as part of periodic tests for non-removable reservoirs.

Pursuant to the UDT Decision (letter TZ-10-1 / 4678/77 dated 17.01.1978), non-removable permanent pressure vessels should be subjected to:

1. Ultrasonic wall thickness measurements in the amount of at least: coat - along 4-ch forming at intervals of measurement points not larger than 0.2 D (D-internal diameter of the tank), bottoms - along 2-d circles at 0.2 D intervals The set of forming circles should cover the areas of the tank in which the worst condition of the wall is expected.
2. Ultrasonic examination of welded joints on sections with a total length of 25% of the length of longitudinal joints and 10% of the length of peripheral joints.
3. Sieves of heat exchangers will be subjected to wall thickness measurements of not less than 4 points and not less than 5% of the number of pipes in the sieve.

According to a letter from UDT Branch in Płock (letter 2044/DO/OC/04/6148002 dated 6.10.2004), permanent permanent pressure tanks with a maximum diameter of DN 1000 can be used to measure wall thickness along 4-fold forming the distance of measurement cross-sections not larger than 500 mm, and if their length / height does not exceed 500 mm - along the four forming in at least two cross-sections. Other decisions of the TZ-10-1/4678/77 Decision remain unchanged.

Test dates are set by the UDT in the revision books.

In the case of testing in accordance with TZ-10-1/4678/77 dated 17.01.1978 or by letter 2044/ DO/OC/04/6148002 dated 6.10.2004, the measurement contractor should enter in the measurement report in the field "scope and basis of the study" the corresponding number of the referenced letter-decision.

2.2.2. The minimum scope of tests required by UDT for pipelines.

According to the UDT letter (letter DT: TC-02406-17 / 05 / KG dated 15.12.2005), depending on the hazard category and the established technical supervision, pipelines reporting to UDT supervision should be subjected to ultrasonic wall thickness measurements in the following quantities:

1. Technological pipelines for the transport of hazardous materials with poisonous, corrosive or flammable properties, for which hazard category I and restricted technical supervision have been established and steam pipelines connecting the boiler with a turbo generator, for which hazard category I or II has been established and limited technical supervision - UDT does not require wall thickness measurements. Wall thickness measurements should be made in case of reasonable concerns about the technical condition or individual recommendations of the UDT Inspector.
2. Technological pipelines for the transport of hazardous materials with poisonous, corrosive or flammable properties, for which II or III hazard category has been established and covered by full technical supervision and steam piping connecting the boiler with a turbo generator, for which I, II or III hazard category and the form of supervision full technical - wall thickness measurement should be performed at least in **4 points** in the cross-section tested, with the number of measurement cross-sections determined:
 - **for I and II hazard category - 2 measurement cross-sections** for at least **10%** of the total number of straight pipeline sections and fittings: knee, arch,

	SAFETY STANDARDS	ORLEN S.A.
Version: January 2024	OCCUPATIONAL HEALTH AND SAFETY EXECUTIVE GUIDELINES FOR CONTRACTORS	Page no.: 46

- **for the III hazard category - 2 measurement cross sections** for at least **20%** of the total number of straight pipeline sections and fittings: elbow, arch, venturi, diffuser, measuring branch (up to DN25) or flange connection, plus one measurement cross-section on each branch member exit ;

Test dates are set by the UDT in the revision books. The locations where wall thickness measurements are taken should be consistent with the highest risk areas identified by RBI analyses (Risk Based Inspection).

The measuring entity should enter in the measurement report under the heading "scope and basis of the test" the reference number of the referenced decision-making letter (DT: TC-02406-17 / 05 / KG of 15.12.2005).

2.3. Activities performed by Technical Infrastructure Department employees on devices subject to UDT supervision.

Technical devices subject to fixed supervision of UDT are subjected to periodic tests (internal review and pressure test) by UDT Inspectors and on dates appointed by them. These tests are carried out in the following periods (with the exception of devices for which the Regulation of the Minister of Economy and Social Policy of July 9, 2003 on technical conditions for technical supervision in the scope of operation of some pressure equipment - Journal of Laws 2003 No. 135 item 1269 - defines other terms):

- a) For apparatuses:
 - internal revision every 3 years,
 - pressure test every 6 years.
- b) For pipelines:
 - main revision every 6 years for the second hazard category and every 3 years for the third hazard category,
 - pressure test every 6 years for II and III hazard category.

For devices subject to permanent UDT supervision, the number and location of wall thickness measurements are determined individually for each device in accordance with the recommendations of the UDT Inspector.

Pursuant to the above mentioned regulation on technical conditions of technical supervision in the scope of operation of some pressure equipment, it is possible to postpone the date of periodic tests by 6 months (in total by 1 year), in technically justified cases, however the request to postpone the test date should be sent to UDT at least 14 days in advance in relation to the date of the examination designated by UDT (entered in the revision book). It is recommended to apply for a postponement of periodic tests in the month preceding the deadline set in the revision book. The application to the UDT for postponing the examination is submitted by the head of the Technical Supervision and Materials Department or a person authorized by him, based on a notification from the User (excluding the Fuel Terminal outside Płock, for which applications are directed by persons directing the Fuel Terminals directly in the appropriate UDT / TDT Branch) . Regardless of the tests performed and recommended by UDT Inspectors, Technical Infrastructure Department employee responsible for devices in the mechanical industry is obliged to perform periodic inspection of the technical device (on site the area of its operation) at intervals of no more than one year. In addition, every 6 years, measurements of the thickness of the apparatus and pipeline connectors with a diameter of <2 "should be performed (if the apparatus or pipeline has more than 10 nozzles, at least 10 nozzles + 50% surplus over 10 nozzles should be tested, if less than 10 nozzles - all) should be examined at least in one cross-section, 4 measuring points each. It is recommended that, as far as possible, periodic inspections performed by SUR employees supervising devices in the mechanical industry are carried out in the middle of the period between reviews designated by UDT. It is allowed to reduce the number of test pieces up

	SAFETY STANDARDS	ORLEN S.A.
Version: January 2024	OCCUPATIONAL HEALTH AND SAFETY EXECUTIVE GUIDELINES FOR CONTRACTORS	Page no.: 47

to 25% given above, for barrier fluid tanks made of austenitic steel, if the working medium is a neutral corrosive medium.

After the activities carried out, the SUR employee supervising devices in the mechanical industry makes an entry in the SZEOR system (function - works / inspections and tests) confirming the performance of the review.

The Technical Passport should be accompanied by copies of all test protocols recommended by UDT Inspectors, but not attached to the revision book and measurement protocols of connections (if they have not been included in the revision book).

For technical devices with limited and simplified supervision, in addition to surveys, the Technical Infrastructure Department employee who supervises the devices in the mechanical industry is obliged to order wall thickness measurements, the first after 6 years of operation, in the following quantities:

a) Apparatuses:

- coat - at least 8 measuring points, in 2 cross-sections of 4 points,
- bottoms - along 2 circles for 4 points,
- stubs, each in at least one section for 4 measuring points,

b) Pipelines:

- straight sections (regardless of the number of welds) - in one cross-section of 4 points,
- fittings (knees, reducers, joints, etc.) - in one cross-section of 4 points,
- stubs, each in at least one section for 4 measuring points,

The next tests should be carried out for a period not longer than 6 years (or shorter if significant corrosion progress has been observed) in the same quantity and in the same places. Measurements should be made in areas where the worst wall condition is expected (according to RBI analysis results). The next measurements should be made in dates and quantities depending on the corrosion progress. The Technical Infrastructure Department employee who supervises the devices in the mechanical industry always analyzes the test results. In the case of identifying consumption approaching the acceptable, UDT informs, in order to obtain a decision on the possibility of further use of the technical device (or determine the scope of the repair).

For devices on which there is a technical possibility to perform tests during the movement of the device, it is recommended to measure the wall thickness before the examination date specified by UDT (in accordance with the rules described in paragraph 6 of the Instruction). All reports on inspections, tests (including those performed before scheduled maintenance shutdowns) and repairs, not included by the UDT inspector in the revision book, should be attached to the Technical Passport.

3. Types of devices subject to the supervision of ITD.

Pursuant to the currently binding ordinance on company technical supervision for ITD supervision, they are subject to:

- pipelines used to transport media with poisonous, corrosive and flammable properties, with a diameter of 50 mm and an operating pressure above 0.6 MPa, built before July 1, 2001.
- pipelines for transporting media with poisonous, corrosive and flammable properties, with a diameter of 50 mm and working pressure above 0.6 MPa, built after July 1, 2001, unless they are eligible for UDT supervision,
- pipelines for the transport of dangerous media such as: chlorine, hydrogen sulfide, ammonia, sulfuric acid, hydrochloric acid, acidic waters with a content of more than 3% H₂S and ammonia water with an ammonia content above 10% of the alkaline solution and acetic acid, regardless of the pipeline diameter and work parameters, built before July 1, 2001,
- pipelines for the transport of dangerous media such as: chlorine, hydrogen sulfide, ammonia, sulfuric acid, hydrochloric acid, acidic waters with a content of more than

 ORLEN	SAFETY STANDARDS	ORLEN S.A.
Version: January 2024	OCCUPATIONAL HEALTH AND SAFETY EXECUTIVE GUIDELINES FOR CONTRACTORS	Page no.: 48

- 3% H₂S and ammonia water with an ammonia content above 10% of the alkaline solution and acetic acid, regardless of the pipeline diameter and work parameters, built after July 1, 2001, unless they are eligible for UDT supervision,
- pipelines for the transport of water vapor and hot water at a temperature above 100 °C, with a pipeline diameter from 50 mm and an operating pressure above 3.2 MPa - except for steam pipelines connecting the boiler with a turbo generator, subject to UDT supervision,
 - pipelines for the transport of oxygen, with a diameter starting from 50 mm and an operating pressure above 0.6 MPa,
 - pipelines made of plastics that meet the above requirements. ground tanks for flammable liquids not recognized by UDT as storage, with a capacity greater than 10 m³, internal overpressure of the gas cushion up to 500 hPa and underpressure up to 10 hPa, intended for storing flammable liquids classified as class I, II or III,
 - hoisting equipment, i.e. hoists not subject to registration at the UDT (simplified supervision), traverses and slings.

3.1. Inspections performed by ITD employees.

3.1.1 Pipelines.

Pipelines subject to fixed supervision of ITD are subjected to periodic tests (basic search and pressure test) by ITD employees in the following periods:

- basic revision every 6 years,
- pressure test every 6 years (obligatory for pipelines are older than 18 years), with the possibility of postponing the examination date by one year, in technically justified cases.

For pipelines that have been carried out (by a team of employees in the area of production and technology) and approved (by the head of the Department) RBI (Risk Based Inspection) analysis, it is allowed to use the terms of basic revisions in accordance with the results of analyzes, but in periods not longer than every 8 years.

The following wall thickness measurements are determined:

Pipeline class according to ZDT / R / 74	Parameters	Number of measuring points
IV	$p > 6,4 \text{ MPa}$ i /lub $T > 450 \text{ }^\circ \text{C}$	8 measuring points for each straight section and each fitting (2 cross-sections of 4 points)
III	$2,0 < p \leq 6,4 \text{ MPa}$ i /lub $200 < T \leq 450 \text{ }^\circ \text{C}$ Club $T < - 40 \text{ }^\circ \text{C}$	4 measuring points for at least 50% of straight sections and fittings (1 cross-section of 4 points)
II	$0,6 < p \leq 2,0 \text{ MPa}$ i $T \leq 200 \text{ }^\circ \text{C}$	2 measuring points for at least 25% of straight sections and fittings (1 cross-section of 2 points)

Measurements should be made in areas where the worst wall condition is expected, with particular attention to small-sized connectors (venting, draining, control and measurement automatics, sampling, etc.). The location of the measurements is determined by the ZDT employee in cooperation with the SUR employee who supervises the devices in the mechanical industry. Subsequent measurements should be made in the same places (where possible identified where the previous measurement was made).

For devices on which there is a technical possibility to perform tests during the movement of the device, it is recommended to perform wall thickness measurements a few months before the scheduled maintenance shutdown.

 ORLEN	SAFETY STANDARDS	ORLEN S.A.
Version: January 2024	OCCUPATIONAL HEALTH AND SAFETY EXECUTIVE GUIDELINES FOR CONTRACTORS	Page no.: 49

The ZDT employee after analyzing the test protocols from subsequent measurements may, depending on the detected rate of corrosion progress, increase or decrease the required number of measuring points and change the date of subsequent tests.

Regardless of the wall thickness measurements, the ZDT employee may recommend other tests to allow for proper assessment of the technical condition.

Protocols with results from all tests, the ZDT employee joins the pipeline review book.

3.1.2. Storage tanks in technological lines.

Storage tanks in process lines subject to fixed supervision of ITD are subject to periodic tests (internal review) by ITD employees and in the following periods:

- tanks used up to 30 years - testing every 10 years,
- tanks used for over 30 years - testing every 6 years,

with the possibility of postponing the examination date by one year in technically justified cases. The following wall thickness measurement range is established:

Coat	1 circumference at a height of 10 cm from the bottom - points every 1 m 2 circumference at a height of 50 cm from the bottom - points every 1 m, last circuit at 50 cm below the roof - points every 1 m other circuits at every 2 m height measuring points every 2 m, but no less than 3 points on each sheet of metal
Bottom	Grid 1 x 1 m, and 1bw 10 cm from the mantle - points every 1 m
Nozzles	Each connector in one cross-section of 4 measuring points
Roof	1 x 1m grid

The ZDT employee after analyzing the test protocols from subsequent measurements (made in the same places) may, depending on the detected rate of corrosion progress,

increase or reduce the required number of measuring points and shorten the time of subsequent tests. Regardless of the wall thickness measurements, the ZDT employee may recommend other tests to allow for proper assessment of the technical condition.

For devices on which there is a technical possibility to perform tests during the movement of the device, it is recommended to measure the wall thickness before the date of examination determined by the ITD (according to the rules set out in paragraph 6 of the Instruction).

Protocols with results from all tests, the ZDT employee joins the revision book of the tank.

The ZDT employee may recommend, as part of an external audit, the execution of wall thickness measurements at the indicated places in an amount not exceeding 10% of the range specified for the internal audit.

Investment services are responsible for:

- making a list of devices with a limited life time and providing guidelines enabling the execution of a test program and material samples for comparative tests,
- completing and submitting technical documentation of devices to ZDT.

4. Rules for reducing the number of measuring points.

For technical devices mentioned in points 3 and 4 of the Instruction (ZDT supervision and Technical Infrastructure Department, supervision), for which at least one wall thickness measurements were made during the device's operation within the scope compliant with the Instruction, a 50% reduction of the number of measurement points provided for in Instructions for a given device, provided that the results of the last thickness measurements do not show any larger than:

	SAFETY STANDARDS	ORLEN S.A.
Version: January 2024	OCCUPATIONAL HEALTH AND SAFETY EXECUTIVE GUIDELINES FOR CONTRACTORS	Page no.: 50

- 20% of the surplus provided for corrosive wear (the difference between the nominal wall thickness and the minimum wall thickness of the element), if the device is used for no longer than 6 years,
- 30% of the surplus provided for corrosive wear, if the device is used for no more than 12 years,
- 40% of the surplus provided for corrosion wear, if the device is used for no more than 18 years,
- 60% of the surplus provided for corrosive wear, if the equipment is used for no more than 30 years.

The analysis of results from previous periods can not show significant changes in the corrosion rate, and the working conditions (including composition of the working medium) have not changed.

The decision about the possibility of reducing the number of measuring points is made individually for each device:

- ZDT inspector - for devices subject to the supervision of ZDT,
- Technical Infrastructure Department employee who supervises devices in the mechanical industry - for devices not subject to supervision by UDT and ZDT.

Wall thickness measurements should be performed in places where the worst wall condition is expected (dead spaces, areas of inhibitor dosing, etc.).

The reduction in the number of measuring points does not apply to:

- small-sized connectors (up to and including 2),
- pipelines for which a pressure test was waived (in accordance with the current regulation on factory technical supervision),
- devices operating in nodes in which there are variable corrosive properties of the medium or increased erosion of the wall material.

5. Testing devices during installation movement.

During the use of technical devices, the User is obliged to:

- operation of devices within the design parameters (pressure, temperature, flow rate) and using the media on which the devices are designed and built,
- daily control of the correct operation of all devices,
- reporting on a regular basis to the maintenance services, any irregularities in the operation of the equipment,
- reporting on an ongoing basis to the maintenance services, any deviations from the technological process parameters for a given device that affect its lifetime (changes in the pH of the medium, changes in the amount and type of corrosion inhibitors, etc.).

During the operation of technical devices, the Technical Infrastructure Department employee who supervises the devices in the mechanical industry is obliged to:

- performance for devices that have a fixed test date for the next maintenance shutdown, any tests that can be performed during the installation's operation. These tests should be carried out 12 to 6 months before the scheduled shutdown of the installation,
- performing, prior to the scheduled shutdown, equipment tests that have a fixed test date for the next maintenance shutdown and which can be individually shut down (without the need to shut down the entire installation) for the time necessary to perform the tests,
- perform the analysis of the results of the tests performed immediately after their execution, and in the case of significant corrosion or other destructive progress, take action to repair or replace the device and report such a case to the ITD and the person performing the function of the Chief Engineer for Reliability.

6. Technological furnaces.

During each scheduled maintenance shutdown (but no more than once every two years) the following steps should be taken:

	SAFETY STANDARDS	ORLEN S.A.
Version: January 2024	OCCUPATIONAL HEALTH AND SAFETY EXECUTIVE GUIDELINES FOR CONTRACTORS	Page no.: 51

- a) Check the condition of the pipe surface, especially at the pipe joints with hangers and limiters.
- b) Check the condition of the hooks holding the coils and the coil tube stops.
- c) Measure the wall thickness of pipes - in accordance with the UDT recommendations.
- d) Check the condition of welded joints. If cracks occur, they should be repaired.
- e) Check the condition of the internal lining of the furnace. Any loss of lining should be completed.
- f) Perform thermal imaging of the furnace coat to determine the condition of the lining. The tests should be performed twice:
 - first test one month before planned renovation (in order to obtain data on lining condition and preliminary determination of the scope of repair),
 - a second test after lining repair (to confirm the effectiveness of the repair).

Reports from thermal imaging studies should be attached to the furnace passport.

Carry out automation blocking tests in accordance with the current regulation on the implementation of the "Instruction for the control and operation of PiA interlock systems in the Production Facility of ORLEN SA in Płock".

After exceeding 70% of project coil working time, it is necessary to carry out tests of the degradation state of the material in order to obtain information on the possibilities of further exploitation.

The Technical Infrastructure Department employee supervising the devices in the mechanical industry fills out the card in which he gives the results of the review and conclusions. Reports on inspections and surveys (with the exception of protocols that the UDT Inspector has joined to the revision book) are attached to the device's passport.

7. Equipment with a limited service life.

7.1. Characteristics of devices.

Under the name of equipment with a limited service life, we should understand objects whose material undergoes increasing deterioration as a result of the creep or corrosion process.

Devices of this type have a defined service life already at the design stage.

7.2. Diagnostic system for device status evaluation.

For devices with a limited service life, tests are carried out in accordance with the test program developed. The list of such devices is prepared by the Investment Services (or users - for devices whose quick consumption resulted during operation) with the participation of Technical Infrastructure Department and forwarded to the Technical Supervision and Material Science Department and a copy to the Director of the Technology Office.

Diagnostic activities should be carried out during operation and during maintenance shutdowns. Device users are required to collect data on the operating conditions of the device during operation (pressure, temperature, changes in the working environment, number of starts, pipeline pulls, etc.).

During maintenance periods, inspections, measurements and tests should be carried out according to the developed testing programs.

For devices operating in creep conditions and for equipment for which it is known at the investment stage that they will be operated in particularly difficult conditions (the device has a fixed service life and is shorter than 20 years), the operational testing program is developed by the Investment Services.

The Investment Services are obliged to commission a diagnostic research program at the stage of their design and production, extending, respectively, the scope of qualitative research constituting a base of output data to determine the degree of degradation of material during operation.

For devices whose service life approaches computational time, and they were not covered by the program of surveys monitoring the material degradation degree, the Technical Infrastructure Department employee supervising devices in the mechanical industry is required to commission (or initiate action) the analysis of the technical condition of the device.

	SAFETY STANDARDS	ORLEN S.A.
Version: January 2024	OCCUPATIONAL HEALTH AND SAFETY EXECUTIVE GUIDELINES FOR CONTRACTORS	Page no.: 52

Such analysis should be performed by a recognized scientific unit in cooperation with the Technical Supervision and Materials Science Department. If the device is under UDT supervision, the testing program should be agreed with its representatives.

- Analysis of the technical condition of the device should include:
- analysis of diagnostic test results,
- analysis of stress state under static loads for characteristic operating conditions of a given device,
- estimation analysis in the field of crack initiation and crack propagation, giving the size of the critical and permissible defect,
- estimation of low-fatigue fatigue strength (determination of the permissible number of water tests, starts and stops, emergency stops, emergency load changes),
- final assessment of the technical condition of the device in relation to the initial state,
- the number of time of further safe operation,
- operational testing program developed together with the Department of Technical Supervision and Materials Science.

In the case of devices operating under degrading conditions of corrosion, the test program should be developed based on the results of at least two consecutive thickness measurements allowing to determine the corrosion rate. The program and scope of tests should be updated after analyzing the results of each subsequent measurement.

8. Tests carried out at the final stage of pipeline construction.

At the final stage of construction (after assembling all the elements together), it is necessary to carry out zero measurements of the wall thickness for pipelines under UDT supervision in the following amount:

1. For the **3rd hazard category**:
 - all knees and joints in 3 sections, 4 measuring points,
 - other elements (straight, venturi, stubs, flange necks) in one cross-section, 4 measuring points each.
2. For the **2nd hazard category**:
 - all knees and joints in 2 cross-sections of 4 measuring points,
 - other elements (straight, venturi, stubs, flange necks) in one cross-section, 4 measuring points each.
3. For the **1st hazard category**:
 - all knees and joints in one cross-section of 4 measuring points,
 - other elements (straight, venturi, stubs, flange necks) in one cross-section, 2 measuring points each.
4. For pipelines transporting **acetic acid** regardless of the parameters and pipeline diameter:
 - all knees and joints in one cross-section of 4 measuring points,
 - other elements (straight, venturi, stubs, flange necks) in one cross-section, 2 measuring points each.
5. For newly built pipelines II and III hazard category and pipelines transporting **acetic acid**, also tests should be performed confirming the grade of material used after the assembly of all pipeline components on the Production Facility (PMI) made in the following quantities:
 - one point on each pipeline element, in accordance with the principles described in paragraph 9 of the Instruction - for pipelines and hazard categories subject to UDT supervision (classification in accordance with Directive 2014/68 / EU)
 - one point on each pipeline element, in accordance with the principles described in paragraph 9 Instructions - for pipelines II and III of the hazard category subject to UDT supervision (classification in accordance with Directive 2014/68 / EU) made of alloy or carbon materials,
 - one point on each element of the flanged pipe body made of alloy materials and installed on the pipeline - for all pipelines,

	SAFETY STANDARDS	ORLEN S.A.
Version: January 2024	OCCUPATIONAL HEALTH AND SAFETY EXECUTIVE GUIDELINES FOR CONTRACTORS	Page no.: 53

- one point on each element and one point on each weld for pipelines transporting acetic acid regardless of the parameters and diameter of the pipeline.

9. Competence of companies performing research.

In the area of ORLEN SA diagnostic tests of the material condition of pipelines, devices and apparatus can be made by:

- Department of Technical Supervision and Materials Science ORLEN S.A.
- Institutes and Universities, in consultation with the Technical Supervision Department of ORLEN SA, operating on the basis of relevant agreements.
- External Testing Laboratories having at least the second level approval of the Central Laboratory of Technical Inspection, operating on the basis of relevant agreements.

10. Technical documentation of inspections and tests.

The technical documentation of inspections and tests is the basic source of information on the technical condition of the device. The way it is run and the scope has a direct impact on the decisions to further allow the device to operate safely.

The technical documentation of inspections and tests, hereinafter referred to as the documentation, is kept by the Technical Infrastructure Department employee supervising the devices in the mechanical industry. It consists of reports from research carried out by research laboratories, service companies authorized to provide diagnostic services on technical devices found in ORLEN S.A.

The documentation is collected:

- for devices subject to UDT supervision - in revision books of these devices in the scope provided for by UDT and in Technical Passports the pattern in accordance with the Maintenance Instructions.
- for devices subject to ZDT supervision - in revision books of these devices in the scope provided for by the ITD requirements and the Maintenance Maintenance Instruction.
- for devices not subject to technical supervision - in Technical Passports (model R100 in accordance with the Maintenance Instructions).

Revision books must be located in a specific place designated by the User on a production installation.

The Technical Passports must be located in a specific place designated by the Technical Infrastructure Department employee who supervises the devices in the mechanical industry or the industry specialist who supervises the technical equipment.

The Technical Passport should contain the following documents:

- technical design (drawings and calculations) for devices not subject to UDT and ZDT supervision,
- As-built documentation along with certificates, material certificates and acceptance protocols for devices not subject to UDT and ZDT supervision,
- any protocols of diagnostic tests having any impact on the determination of the technical condition of the device (for devices subject to UDT supervision to the passport should be included only those protocols, which the Inspector of UDT did not join the revision book),
- seal replacement cards.

Requirements to be met by test protocols collected in technical passports:

- protocols must be prepared for each device separately, and in the case of diagnostic tests conducted comprehensively for a larger number of devices, there must be information in each portfolio of the technical passport indicating where the protocols with attachments relating to this device are located,

	SAFETY STANDARDS	ORLEN S.A.
Version: January 2024	OCCUPATIONAL HEALTH AND SAFETY EXECUTIVE GUIDELINES FOR CONTRACTORS	Page no.: 54

- the results of measurements must be designed in a form that ensures unambiguous identification of all measuring points. The principle of performing further measurements at the same points should be applied. For pipelines, please use copies of drawings from the project documentation. The next measurements should be related to the same drawing with the measured points,
- the measurement results must be statistically processed, i.e. they must contain min. and max. in individual axes and average values, as well as must contain visible markings of results with values exceeding the limit values,
- wall thickness measurements must be entered into the SZEOR electronic archiving system. The introduction of wall thickness measurement results to the SZEOR system does not exempt measurement contractors from the obligation to provide written protocols with the results of measurements made in the form of a report specified in the procedure (instruction) approved by a notified body that gave the authority to perform thickness measurements.

20. Regulation regarding the occupational health and safety requirements for employees at workplaces where explosive atmospheres may occur at the ORLEN S.A.

For workplaces where the possibility of an explosive atmosphere threatening the health and life of workers is suspected, it is necessary to classify areas endangered by explosion and make a "Explosion risk assessment" based on it. The explosion risk assessment is an integral part of the Explosion Protection Document called the Ex Document.

The explosion risk assessment should include at least:

- assessment of the probability and time of occurrence of an explosive atmosphere;
- assessment of the probability of occurrence and activation of ignition sources, including electrostatic discharges;
- assessment of the interaction of the operation units, the substances and mixtures used and the processes involved;
- assessment of the size of the anticipated (possible and undesirable) effects of the explosion.

Identification of explosive atmospheres

Characteristics of hazardous substances in terms of explosives

List and characteristics of explosive hazardous materials developed based on Ex approved and accepted classification cards for hazardous areas (Annex No. 19).

Classification of potentially explosive atmospheres

List and classification of potentially explosive atmospheres prepared on the basis of Ex approved and accepted classification cards for hazardous areas (Annex no.20).

Explosion risk assessment

The probability of occurrence of effective sources of ignition

It is recommended to classify effective ignition sources, taking into account the probability of their occurrence as follows:

- sources of ignition that can occur continuously / continuously or frequently ($100 - 10^{-2}$)
- sources of ignition that may rarely occur ($10^{-3} - 10^{-5}$)
- sources of ignition that may occur exceptionally ($10^{-6} - 10^{-7}$)

	SAFETY STANDARDS	ORLEN S.A.
Version: January 2024	OCCUPATIONAL HEALTH AND SAFETY EXECUTIVE GUIDELINES FOR CONTRACTORS	Page no.: 55

The analysis should cover all types of ignition sources given in the PN-EN 1127-1 standard, determine their effectiveness and probability of occurring in the considered space using the risk matrix.

Note: we assume higher probability values to estimate the explosion risk

The probability of an explosive atmosphere

We estimate the likelihood of an explosive atmosphere based on the risk matrix and present it in the table below:

Type of explosion hazardous area	Description of the zone	Duration	Probability of atmosphere occurring
Zone 0	A space in which an explosive atmosphere containing a mixture of combustible substances, in the form of gas, steam or mist with air, occurs continuously or in long periods	>1000 hour/year	$10^{-1} \div 1$
Zone 1	A space in which an explosive atmosphere containing a mixture of combustible substances with air can sometimes occur under normal operating conditions	10÷1000 hour/year	$10^{-3} \div 10^{-2}$
Zone 2	A space in which in the conditions of normal operation the appearance of an explosive gas atmosphere does not occur, and in the case of occurrence, it is short-lived	1÷10 hour/year	$10^{-4} \div 10^{-3}$

Note: we assume higher probability values to estimate the explosion risk.

Determination of explosion risk

To estimate the explosion risk, the process risk matrix included in the regulation on the introduction and application of the Process Safety Management System at the ORLEN SA is used.

Attention:

The probability of an explosion is the product of the probability of the appearance of effective ignition sources and the occurrence of an explosive atmosphere.

 ORLEN	SAFETY STANDARDS	ORLEN S.A.
Version: January 2024	OCCUPATIONAL HEALTH AND SAFETY EXECUTIVE GUIDELINES FOR CONTRACTORS	Page no.: 56

Category of consequence (S)		Frequency - 1/year (P)	numeric designation	negligible	low	average		high	disaster
				1	2	3		4	5
<i>very often</i>	<10 ⁰ – 10 ⁻¹)	1	TA	TNA	NA			NA	NA
<i>often</i>	<10 ⁻¹ – 10 ⁻²)	2	TA	TNA	TNA			NA	NA
<i>possible</i>	<10 ⁻² – 10 ⁻³)	3	TA	TA	TNA			TNA	NA
<i>sporadic</i>	<10 ⁻³ – 10 ⁻⁴)	4	A	TA	TA			TNA	TNA
<i>rare</i>	<10 ⁻⁴ – 10 ⁻⁵)	5	A	A	TA			TA	TNA
<i>very rare</i>	<10 ⁻⁵ – 10 ⁻⁶)	6	A	A	A			TA	TA
<i>nearly impossible</i>	<10 ⁻⁶ – 10 ⁻⁷ >	7	A	A	A			A	A

Where the resulting risk level (R) is determined by:

- A** Risk accepted (in theory no additional security measures are required, however, they may be indicated for implementation),
- TA** Risk tolerated - accepted (ALARP principle, review the alternatives)
- TNA** Accepted unacceptable risk (introduce additional security measures on a separate date)
- NA** Unacceptable risk (stop the process immediately)

Categories of effects:

Effects	Employees	Population	Environment	Wealth	Reputation
negligible	No injuries	No injuries	No influence	Up to 10 000 €	No influence
Small	Single minor injuries Not affecting the performance of work or causing inability to work)	Odor, noise (No evacuation nor first medical aid required)	Small recorded in reports Light environmental damage within the installation)	Up to 100 000 €	A slight impact (undermined trust - possible to recover quickly at low cost. Public awareness may exist)

 ORLEN	SAFETY STANDARDS	ORLEN S.A.
Version: January 2024	OCCUPATIONAL HEALTH AND SAFETY EXECUTIVE GUIDELINES FOR CONTRACTORS	Page no.: 57

Effects	Employees	Population	Environment	Wealth	Reputation
average	Average injuries, single severe injuries <i>(Limiting performance of duties or a few days absence for full recovery, small, reversible health effects, eg skin irritation, food poisoning)</i>	Small injuries <i>(No evacuation required, first medical aid required)</i>	Average damage <i>(Noticable damage or emission to the environment, but no lasting effect, single case of violation of a statutory restriction or a single complaint)</i>	Up to 1.000 000 €	Limited impact <i>(Conflicted trust - possible to regain in the long term with PR support. Unpleasant attention of local media / political groups)</i>
high	Numerous heavy injuries <i>(Irreversible health effects with serious inability to work, for example: caustic burns, loss of hearing due to detonation noise, heat stroke)</i>	Average injuries <i>(Limited health effects for people, not required evacuation, medical assistance required for individual cases)</i>	Serious destruction <i>(The company must undertake comprehensive measures to rebuild environmental damage, the extent of damage violates statutory restrictions)</i>	Up to 10 000 000 €	National influence <i>(Significant drop in confidence - trust that can be recovered in the long term, but at a high cost. Extensive, unfavorable national media attention)</i>
disaster	Fatalities <i>(Single or collective fatal accident)</i>	Serious injuries <i>(Irreversible health effects, required evacuation and medical help for a large number of people)</i>	Ecological disaster <i>(Permanent and serious damage to the environment resulting in large financial consequences for the Company, ongoing effects seriously violate statutory restrictions)</i>	Above 10 000 000 €	International influence <i>(Seriously tarnished confidence - impossible to recover fully. International public attention, extensive, unfavorable international media attention)</i>

The result of the explosion risk assessment should be presented in the table. (Annex No.21a.)

List of potentially explosive workplaces

The list of potentially explosive workplaces should be presented in the table. (Annex No. 22.)

Measures to prevent the occurrence of explosive threats and to limit the effects of an explosion

 ORLEN	SAFETY STANDARDS	ORLEN S.A.
Version: January 2024	OCCUPATIONAL HEALTH AND SAFETY EXECUTIVE GUIDELINES FOR CONTRACTORS	Page no.: 58

The following is a sample of an example table:

Item	Workplace	Explosion prevention agent used	The date of the review	Responsible person
1				
2				

Specification of explosion-proof devices

Specify the specification of explosion-proof devices installed on the site - mechanical, electrical, automatic, teleinformatic. It is necessary to apply to all industries for providing specimens of device specification tables - Annex No. 23.

List of certificates for explosion-proof devices

The list of certificates for explosion-proof devices should be prepared with the division into individual industries - mechanical, electrical, automatic, teleinformatic as per Annex 24.

21. Regulation regarding the classification of areas with potentially explosive atmospheres in ORLEN S.A. and the ORLEN Capital Group.

The scope regarding the classification of areas with potentially explosive atmospheres is included in the Technical Requirements of the Electric Industry (issue 2.7 or later), pt 2.5. provided to the Contractor.

22. Regulations regarding implementation of the Instruction for the carriage of dangerous goods by land transport on the premises of ORLEN S.A. and for the benefit of ORLEN S.A.

Inland transport of dangerous goods is subject to the provisions resulting from the Agreement on the international carriage of dangerous goods by road – ADR and the Regulations of the international carriage of dangerous goods by rail – RID. The ordinance describes the conditions for transporting and performing operations with cargo containing dangerous goods, appropriate marking of packaging and means of transport of dangerous goods, required documents accompanying transport and necessary equipment of transport units.

The provisions concern:

- the sender of dangerous goods,
- recipient of dangerous goods,
- dangerous goods carrier,
- shippers and unloaders of dangerous goods,
- filler of dangerous goods,
- tank container operator.

Dangerous Goods Transport Team (PBN) holds the coordinating and concluding function in the area of transport of dangerous goods in ORLEN SA.

Until January 30th of every year, persons managing organizational units responsible for the sending, purchase, sale, loading, unloading, packaging, filling and transport of dangerous goods are obliged to send to the Dangerous Goods Transport Team proper materials necessary to prepare the Annual Report. In case of the release/ spillage of dangerous goods, imminent threat of such release, personal injuries, material damage, destruction of the environment or the

	<p style="text-align: center;">SAFETY STANDARDS</p>	<p style="text-align: center;">ORLEN S.A.</p>
<p>Version: January 2024</p>	<p style="text-align: center;">OCCUPATIONAL HEALTH AND SAFETY EXECUTIVE GUIDELINES FOR CONTRACTORS</p>	<p style="text-align: center;">Page no.: 59</p>

involvement of competent authorities, the managers of organizational units are obliged to immediately inform the Dangerous Goods Transport Team in order to prepare a Report on events occurring during the carriage of dangerous goods.

Transportation of dangerous goods by road

Obligations of participants in the transport of dangerous goods

1. **The Sender** of dangerous goods is obliged to deliver for transport only such shipments that meet the requirements of the ADR Agreement, in particular he is obliged to:
 - ensure that the dangerous goods are classified and approved for transport in accordance with the ADR,
 - before the departure of the transport unit carrying dangerous goods, provide the driver with the required shipping documents and accompanying documents, taking into account all the requirements in accordance with the ADR Agreement and other regulations,
 - use only packaging that complies with the requirements of the ADR Agreement for individual dangerous goods;
 - check the requirements for shipping methods and shipping limitations specified in the ADR Agreement.

If the Sender uses the services of other transport participants (Packer, Loader, Filler, etc.), he must make sure that all legal requirements have been met. It may happen that the Sender of dangerous goods will be another entity with which ORLEN S.A. has an appropriate commercial contract. The indicated entity will have a separate contract of carriage with its Carrier. In this case, ORLEN S.A. must inform this Sender in writing of the fact that the transport concerns dangerous goods and should provide the Sender with all information and documents needed to fulfill its obligations. This information must be included in the commercial contract governing the transport of dangerous goods.

2. **The Carrier** is obliged in particular to:
 - provide transport units that meet the requirements of the ADR Agreement for the transport of a given dangerous goods;
 - check that all the information required in the ADR Agreement, relating to dangerous goods intended for transport, has been provided by the Sender prior to its commencement;
 - check that the vehicle-tank and the load have no obvious defects and that there are no leaks;
 - check that the transport unit is not overloaded;
 - make sure that the transport unit is labeled with warning stickers, signs and orange plates indicated in the ADR Agreement for a given dangerous goods;
 - have the equipment in the transport unit required by the ADR Agreement.

The above activities must be performed on the basis of the shipping documents and accompanying documents, as well as visual inspection of the transport unit and the load. If, by performing the aforementioned activities, the Carrier finds a breach of the requirements of the ADR Agreement, it may not start the transport, and is obliged to inform the Sender about the inconsistencies. In this situation, participants in the transport are obliged to remedy the non-compliance in accordance with their obligations. Transport may commence only after all non-conformities have been remedied. The Carrier is obliged to provide the vehicle crew with written instructions specified in the ADR Agreement. The Carrier of dangerous goods is obliged to appoint an authorized ADR Advisor.

3. **The Shipper** is obliged in particular to:
 - make sure before loading that the goods prepared for loading are approved for transport in accordance with the ADR Agreement;
 - when issuing packaged dangerous goods or empty uncleaned packages for transport, check that the packages are not damaged and that there are no visible leaks;
 - act in accordance with the special provisions contained in the ADR Agreement regarding loading and handling of cargo.

	SAFETY STANDARDS	ORLEN S.A.
Version: January 2024	OCCUPATIONAL HEALTH AND SAFETY EXECUTIVE GUIDELINES FOR CONTRACTORS	Page no.: 60

If the loading activities are performed by another company on the basis of a separate agreement with ORLEN S.A., the information on taking over the responsibility for the loading of dangerous goods must be included in the commercial agreement.

4. **The Packer**, when packages are packed, shall in particular comply with:

- the requirements for packing conditions, including packing together, which are set out in the ADR Agreement;
- requirements for marking and the use of warning stickers, as specified in the ADR Agreement.

If the packing activities are performed by another company on the basis of a separate agreement with ORLEN S.A., the information on taking over the responsibility for the packing of dangerous goods must be included in the commercial agreement.

5. **The Filler** is obliged in particular to:

- be certified to fill transport tanks with dangerous goods of a certain class;
- make sure that the vehicle-tank, tanker, container, MEGC are correctly selected for the goods being filled, in accordance with the requirements of the ADR Agreement;
- before filling, check the technical condition and equipment of the unit based on a visual inspection;
- check the validity of the technical inspection required by the provisions of the ADR Agreement on the rating plate;
- when filling the tanker, comply with the requirements for loading hazardous materials into adjacent chambers of the tanker;
- fill the tankers in accordance with the maximum permissible degree of filling;
- after filling the tanker, make sure that all closures are in the closed position and that there is no leakage;
- after filling the tanker, check that there is no residue of the filled material on the external surface of the filled tanker;
- after filling the tanker, check whether the transport unit is labeled in accordance with the ADR Agreement.

If the filling activities are performed by another company on the basis of a separate agreement with ORLEN S.A., the information on taking over the responsibility for the filling of dangerous goods must be included in the commercial agreement.

6. **The Unloader** is obliged in particular to:

- check before unloading that the correct goods have been delivered by comparing the relevant information in the shipping document with the information on the package or shipping unit;
- check before and during unloading that the packages or the transport unit are not damaged;
- immediately after unloading the transport unit, remove all dangerous residue of goods that adhered to the outer surface of the transport unit during unloading operations.

If the unloading activities are performed by another company on the basis of a separate agreement with ORLEN S.A., the information on taking over the responsibility for the unloading of dangerous goods must be included in the commercial agreement.

Control over the transport of dangerous goods

On the premises of ORLEN S.A., inspections are carried out on the conditions and methods of transport, loading and unloading of dangerous goods.

In the event of finding deficiencies related to the requirements of the ADR Agreement, the transport unit may not be loaded until the identified irregularities are removed. The inspector notifies the person responsible for the organization of the transport. The person dealing with the organization of a given transport is obliged to notify the Carrier in writing about the irregularities and about the need to remove them or to order a replacement transport unit that meets the requirements of the ADR Agreement.

Operationally, when it is not possible to remove non-conformities on site:

	SAFETY STANDARDS	ORLEN S.A.
Version: January 2024	OCCUPATIONAL HEALTH AND SAFETY EXECUTIVE GUIDELINES FOR CONTRACTORS	Page no.: 61

- a) vehicle inspection takes place before loading/ the vehicle is being loaded - the vehicle cannot be allowed to be loaded/filled; loading operations must be interrupted and the vehicle must be unloaded,
- b) the vehicle is loaded/filled - the vehicle must be unloaded.

For found discrepancies, the vehicle is banned from entering the premises of ORLEN SA to all locations in Poland until the discrepancies are removed.

After removing the discrepancies, the carrier informs the transport organizer about this fact and sends an e-mail to doradcy.DGSA@orlen.pl with confirmation of removing the discrepancies, after which the entry for a given vehicle on the ORLEN S.A. premises will be re-granted.

Transportation of dangerous goods by rail

Obligations of participants in the transport of dangerous goods

1. The Sender of dangerous goods is obliged to deliver for transport only such shipments that meet the requirements of the RID Regulations, in particular he is obliged to:

- ensure that the dangerous goods are classified and approved for transport in accordance with the RID,
- before the departure of the cargo transport unit carrying dangerous goods, provide the driver with the required shipping documents and accompanying documents, taking into account all the requirements in accordance with the RID Regulations and other regulations;
- use only wagons and tankers (in particular, wagons-tankers, wagons with removable tanks, MEGCs, portable tanks and containers-tankers) that have been approved and suitable for the transport of the given materials and have the marking provided for in RID;
- check the requirements for the methods of sending and shipping restrictions specified in the RID Regulations;
- ensure that the empty, uncleaned and ungasped tanks are properly labeled, closed and as tight as when loaded,

It may happen that the Sender of dangerous goods will be another entity with which ORLEN S.A. has an appropriate commercial contract. The indicated entity will have a separate contract of carriage with its Carrier. In this case, ORLEN S.A. must inform this Sender in writing of the fact that the transport concerns dangerous goods and should provide the Sender with all information and documents needed to fulfill its obligations. This information must be included in the commercial contract governing the transport of dangerous goods.

2. The Carrier is obliged in particular to:

- make sure that all information required by the RID Regulations for the transported dangerous goods has been provided by the Sender prior to transport and that the required documents are attached to the transport document;
- visually check that the wagons and the load have no visible defects, leaks, cracks and lack of equipment;
- make sure that the deadline for the next test for wagons and tankers (in particular tank wagons, battery wagons, wagons with removable tanks, portable tanks, tank-containers and MEGCs) has not expired;
- check that the wagons are not overloaded;
- make sure that the required marking has been placed on the wagons, i.e. large warning stickers, orange signs and plates;
- make sure that the equipment specified in the RID Regulations is in the driver's cab.

The above activities must be performed on the basis of the shipping documents and accompanying documents, as well as visual inspection of the transport unit and the load. If, by performing the

	SAFETY STANDARDS	ORLEN S.A.
Version: January 2024	OCCUPATIONAL HEALTH AND SAFETY EXECUTIVE GUIDELINES FOR CONTRACTORS	Page no.: 62

aforementioned activities, the Carrier finds a breach of the requirements of the RID Regulations, it may not start the transport, and is obliged to inform the Sender about the inconsistencies. In this situation, participants in the transport are obliged to remedy the non-compliance in accordance with their obligations. Transport may commence only after all non-conformities have been remedied. The Carrier is obliged to provide the vehicle crew with written instructions specified in the RID Regulations. The Carrier of dangerous goods is obliged to appoint an authorized RID Advisor.

3. The Filler is obliged in particular to:

- be certified to fill transport tanks with dangerous goods of a certain class;
- make sure that the wagon or tanker (in particular a wagon with removable tanks, MEGC, portable tanker and container - tanker) are correctly selected for the goods being filled, in accordance with the requirements of the RID Regulations;
- make sure that the deadline for the next test for a wagon or a tanker, in particular wagons - tankers, battery wagons, wagons with removable tanks, portable tanks, containers - tankers and MEGCs) has not expired;
- before filling, on the basis of a visual assessment, check the technical condition and equipment of wagons and tankers (in particular wagons - tankers, battery wagons, wagons with removable tanks, portable tanks, containers - tankers and MEGCs);
- when filling wagons and cisterns (in particular wagons - tankers, battery wagons, wagons with removable tanks, portable tanks, containers - tankers and MEGCs) apply the requirements for loading hazardous materials into the adjacent tanker's chambers;
- fill wagons or cisterns (in particular wagons - tankers, battery wagons, wagons with removable tanks, portable tanks, containers - tankers and MEGCs) in accordance with the maximum permissible degree of filling or the permissible mass of contents per liter of capacity;
- after filling, make sure that all closures are in the closed position and that there is no leakage;
- after filling, check that there are no residues of the filled material on the external surface of the filled wagons or tankers (wagons - tankers, battery wagons, wagons with removable tanks, portable tanks, containers - tankers and MEGCs);
- after filling wagons or cisterns (in particular wagons - tankers, battery wagons, wagons with removable tanks, portable tanks, containers - tankers and MEGCs) check whether the marking has been placed in accordance with the RID Regulations.

If the filling activities are performed by another company on the basis of a separate agreement with ORLEN S.A., the information on taking over the responsibility for the filling of dangerous goods must be included in the commercial agreement.

4. The Unloader is obliged in particular to:

- check before unloading that the correct goods have been delivered by comparing the relevant information in the shipping document with information on wagons or tanks (in particular wagon - tankers, battery wagons, wagons with removable tanks, portable tanks, container - cisterns and MEGCs);
- check, before and during unloading, that the tanker, wagon or container has not been damaged;
- immediately after unloading, remove all dangerous residue of goods that adhered to the outer surface of wagons or tankers during unloading activities (in particular wagons - tankers, battery wagons, wagons with removable tanks, portable tanks, containers - tankers and MEGCs).

If the unloading activities are performed by another company on the basis of a separate agreement with ORLEN S.A., the information on taking over the responsibility for the unloading of dangerous goods must be included in the commercial agreement.

	<p style="text-align: center;">SAFETY STANDARDS</p>	<p style="text-align: center;">ORLEN S.A.</p>
<p>Version: January 2024</p>	<p style="text-align: center;">OCCUPATIONAL HEALTH AND SAFETY EXECUTIVE GUIDELINES FOR CONTRACTORS</p>	<p style="text-align: center;">Page no.: 63</p>

Control over the transport of dangerous goods

In Orlen S.A. inspections are carried out on the conditions and methods of filling, transport, unloading and dispatch of dangerous goods. If any deficiencies related to the requirements of the RID Regulations are found, transport cannot take place until the identified irregularities are removed. The inspector notifies the person responsible for the organization of the transport. The person responsible for the organization of a given transport is obliged to notify the Carrier in writing of any irregularities and the need to remove them.

In-house transport of technical gas cylinders

The contractor performing activities on the premises of ORLEN SA is obliged to comply with the guidelines for safe intra-plant transport of cylinders with technical gases.

When properly transporting technical gas cylinders, you should in particular:

- cylinders with technical gases should only be transported on vehicles with an open or ventilated body,
- place the cylinders on the vehicle so that they do not protrude beyond the outline on the side and rear of the vehicle,
- transport cylinders with technical gases only in a standing position,
- cylinders with technical gases must be secured so that they cannot move or collide while driving. During transport, cylinders must have functioning valves, which must be protected with a screwed protective cap,
- when transporting cylinders with technical gases, all auxiliary devices such as reducers, pressure gauges, welding hoses, etc. must be dismantled.

It is not allowed to transport loaded or empty cylinders in the driver's cabin or in passenger vehicles. Pulling or towing welding trolleys not approved for road traffic using various types of vehicles is not allowed.

If irregularities are found related to the internal transport of cylinders with technical gases, the transport should be suspended until the irregularities are removed.

23. Regulation on the location of temporary facilities and organization of construction sites for Contractors on the premises of the Production Facility in Płock, the PTA Facility in Włocławek, CCGT Włocławek or adjacent areas".

Definitions:

- Construction - construction of a building in a specific place, as well as reconstruction, extension, superstructure and reconstruction of a building;
- temporary smoking room - a place for smoking tobacco designated in accordance with the Fire and Chemical Safety Regulations of ORLEN S.A.;
- construction site - a separate place intended for construction works (erecting, renovation or demolition of buildings);
- renovation works - performing construction works in an existing building that consist in restoring the original state, and not constituting ongoing maintenance, it is allowed to use construction products other than those used in the original state;
- construction works - construction, as well as works involving the reconstruction, extension, superstructure, assembly, renovation or demolition of a building;
- prevention services - employees of organizational units reporting to the Head of the Occupational Health and Safety Office, the Head of the Inspection and Safety Office, the Head of the Environmental Protection Office and employees of ORLEN Ochrony Sp. z o. o. and ORLEN Eko Sp. z o. o. – performing the tasks of the health and safety service, fire protection and environmental protection;

	SAFETY STANDARDS	ORLEN S.A.
Version: January 2024	OCCUPATIONAL HEALTH AND SAFETY EXECUTIVE GUIDELINES FOR CONTRACTORS	Page no.: 64

- construction site - the space where construction works are carried out, including the space occupied by construction site facilities;
- temporary facility - a structure intended for temporary use for a period shorter than its technical life, intended for transfer to another location or demolition, as well as a structure not permanently attached to the ground, such as: tent covers, barracks, container facilities;
- Land owner - a person managing an organizational unit to whom a relevant part of the Company's land in Płock has been assigned, where the assets held by the organizational unit are located;
- Contractor - a natural person or a legal person who, on the basis of a contract concluded with ORLEN S.A., performs repair or investment services;
- Back-up facilities - permanent or temporary facilities related to the development of the land or construction site, necessary for the performance of the assumed tasks;
- permanent facilities - facilities related to land development or construction site necessary for the implementation of commissioned by ORLEN S.A. repair, assembly, service works, etc. based on concluded contracts for an indefinite or long-term period;
- temporary facilities - facilities of contractors of external companies related to land development or construction site in the area made available to enable the provision of contracted services.

1. Temporary facilities located on the premises of the Production Facility in Płock, PTA Facility in Włocławek, CCGT Włocławek or adjacent areas for Contractors with contracts for the implementation of repair services or contracts for the implementation of works under investment projects.
2. Temporary facilities may be located within the production Facility in Płock, PTA Facility in Włocławek, CCGT Włocławek Facility or adjacent areas only on the basis of a contract for repair, periodic, planned, current, framework, technological services or for investment projects concluded between ORLEN ARE a Contractors or tenancy / lease / access agreements.
3. The Contractor who meets the provisions of point 1 - 3 applying for temporary location of facilities in the area and within the Production Facility in Płock, PTA Facility in Włocławek, CCGT Włocławek Facility or adjacent areas obtains the required approvals from the Employer and the Designer's Main Department, requested by the completed form "Permission for temporal placement for Contractor's facilities "
4. The Contractor shall be required to obtain the approval of the back-up facility's location by the Site Owner or the area designated by the Owner
5. The duration of the back-up facility's functioning time is valid with the deadlines specified in the contract for the performance of renovation or investment works, including the time provided for mobilization and demobilization.
6. The Contractor, applying for a temporary location of the back-up facilities in the areas and within the production plant in Płock, PTA Plant in Włocławek, CCGT Włocławek Plant or in the adjacent areas, obtains the required approvals from the Ordering Party and the Office of Spatial Information and Design Analysis, Water and Sewage Plant and the IT Infrastructure Office for which he applies on the basis of the completed form "Permission for the temporary location of the Contractor's back-up facilities", "Report of land transfer", "Contractor's Statement" and "Map for illustrative purposes" received from the Department of Geodetic and Cartographic Documentation with a drawn area of the back-up facility that has been booked on time in the numerical map system.
7. Each permit for the temporary location of the Contractor's back-up facilities is recorded by the Department of Technical Infrastructure and Settlements of Repairs after the delivery of a set of documents and the required opinions/consents.
8. The Contractor is responsible for the area taken over along with the facilities, until the completion of works and a formal return of the area with the surrounding areas.

	SAFETY STANDARDS	ORLEN S.A.
Version: January 2024	OCCUPATIONAL HEALTH AND SAFETY EXECUTIVE GUIDELINES FOR CONTRACTORS	Page no.: 65

9. Waste generated in the construction/renovation process should be selectively stored, removed from the construction site and managed in accordance with applicable regulations and arrangements included in the contract. The recommended cycle of removing waste generated by the Contractor from the construction site is 7 calendar days.
10. It is strictly forbidden to create permanent waste dumps and storage places for any waste in the back-up facilities and its surroundings.
11. Waste generated in the construction/ renovation process should be selectively stored, removed from the construction site and managed in accordance with applicable regulations and arrangements contained in the contract. Recommended removal cycle from the construction site is 7 calendar days.
12. The Contractor's duties include equipping the back-up facility with a container for municipal waste as well as designating and marking a place for temporary storage of waste.
13. The contractor is obliged to ensure the collection of municipal waste on its own by signing a contract for the collection of selectively collected waste with an authorized company operating in a given area.
14. To use the media in the back-up facility, it is required to conclude agreements with service providers and to cover their costs by the Contractor.
15. The Contractor shall be liable under general rules provided for by civil law for damages resulting from acts or omissions in relation to equipment and installations of ORLEN SA located on the given square or area - from the moment of its acceptance until the moment of formal return.

Conditions for temporary back-up facilities

1. The facilities located on the premises of the Production Facility in Płock, PTA Facility in Włocławek, CCGT Włocławek Facility or on adjacent areas should be fenced off with an openwork fence in such a way as to prevent outsiders access to the back-up facility.
2. It is allowed not to fence the facilities for carrying out renovation works, as agreed with the landowners/ users or for investment works in accordance with arrangements with appropriate Implementers or Project Implementation Managers in consultation with landowners, which does not absolve the Contractor from responsibility for the facilities and the area taken over.
3. After taking over the area (square), the Contractor is responsible for organizing the facilities and utilities necessary for the functioning of the temporary facilities.
4. Each object, temporary facilities should have a visible yellow information board giving:
 - name of the Contractor,
 - name and surname of the person responsible for the object,
 - 24-hour telephone to the person responsible for the back office.
5. Fenced or back-up areas that will not have an information board will be considered abandoned property.
6. The facilities should be located at such a distance from:
 - a) designated Ex-zones,
 - b) main lanes, networks and utilities,
to ensure maximum safety of employees
7. Back-up facilities should have developed fire protection conditions agreed with the Commander of the Company Fire Brigade and meet the following criteria:
 - a) the location of min. 2m. outside the designated danger zone specified in the classification documentation for potentially explosive atmospheres;
 - b) it is possible to locate a flap in a potentially explosive atmosphere during a shutdown or overhaul, provided that the hydrocarbon installation is empty inside a designated explosion hazard zone;
 - c) distance from other objects including tracks - min. 8 m,

	SAFETY STANDARDS	ORLEN S.A.
Version: January 2024	OCCUPATIONAL HEALTH AND SAFETY EXECUTIVE GUIDELINES FOR CONTRACTORS	Page no.: 66

- d) as a rule, it is assumed that the back-up facilities will consist of max. three barracks or other rooms marked with the company's name, with a total area of up to 50 m², for one Contractor;
 - e) in case of the need to increase the number of facilities, justification is required, confirmed by the ordering party;
 - f) outside the facilities mentioned in point 7d. the distance of at least 4m must be kept;
 - g) distance from the main road - at least 5 meters from the road gauge, and no elements can limit the visibility of the drivers moving on the road.
8. In order to ensure sufficient visibility at intersections of main roads, it is forbidden to set containers and crewmen at a distance of less than 15 m from the road gauge.
 9. It is forbidden to set containers acting as social facilities under main flyovers and torches.
 10. It is forbidden to place containers and caravans serving as social facilities on sewage manholes.
 11. It is forbidden to place containers and caravans serving as social facilities on manholes of any sewage systems, including telecommunications sewage systems, primary telecommunications sewage pipes and telecommunications cables.
 12. It is allowed to smoke in temporary smoking rooms in the back-up facilities, provided that a long-term permit has been issued to carry out works within the temporary back-up facilities and it is specified in the concluded contract. The location and the room itself intended for smoking rooms must receive a positive opinion of the Company Fire Brigade.
 13. Facilities must be equipped with hand-held fire-fighting equipment in accordance with KSP, but not less than 1 unit of fire-fighting equipment type GP-6x/ABC or larger for each truck or other compartment. The deployed firefighting devices should be conveniently accessible during the operation of the back-up facilities.
 14. Back-up facilities should be located in such a way to maintain access to the devices protecting the installation - leaving space not less than 2m.
 15. Temporary facilities should be located on a paved area or should be equipped with sleepers preventing them from settling in the ground.
 16. The Contractor is obliged to:
 - a) exercise general supervision over the conduct and compliance with the regulations as well as OSH and fire protection rules,
 - b) provide "Instruction of behavior in the event of a fire", in barracks or other rooms
 - c) maintain cleanliness and order in the subordinate area,
 - d) comply with the conditions that should be met by the area or facilities,
 - e) protect of trees, technical infrastructure and other elements of development located at the area or in the facilities,
 - f) safe storage of technical gases in accordance with OHS and fire regulations, rules and standards of ORLEN S.A.
 - g) possession of the current "Permit for the temporary location of the Contractor's back-up facilities" in the back-up facility for possible inspection by employees of the prevention services.
 17. To the extent related to the performance of works in the vicinity of the existing telecommunications and teletechnical infrastructure, the following conditions must be observed when creating temporary or permanent facilities:
 - a) In places close to the existing network, keep at least 0.5 m from the gauge of the existing sewage system and teletechnical cables,
 - b) Before commencing the works, control excavations should be made in order to confirm the exact location of the existing telecommunications infrastructure,
 - c) Excavations closer than 0.5 m from the gauge of the existing telecommunications duct or cable should be protected against sliding and uncontrolled breaking of the active

	SAFETY STANDARDS	ORLEN S.A.
Version: January 2024	OCCUPATIONAL HEALTH AND SAFETY EXECUTIVE GUIDELINES FOR CONTRACTORS	Page no.: 67

- telecommunications infrastructure. The concept of security and its physical implementation is subject to the approval of the IT Infrastructure Office,
- d) All works within the existing teletechnical network should be carried out manually under the supervision of the IT Infrastructure Office and comply with applicable health and safety regulations, PN and appropriate for earthworks at the production plant in Płock Regulations of the General Director in this regard,
 - e) Prior to commencing the works, appropriate (required) consents and permits for the works in question must be obtained,
 - f) In the event of a possible need to reconstruct the teletechnical duct and the cables contained therein, the contractor of the task will perform appropriate works on the teletechnical network at his own expense. Before backfilling the completed elements (within the teletechnical network), the disappearing works are subject to acceptance by a representative of the IT Infrastructure Office. Upon completion of the works, as-built documentation should be prepared along with geodesic changes that occurred during the implementation. The documentation will be subject to substantive verification and obtaining a positive opinion of the IT Infrastructure Office,
 - g) Failure by the contractor to submit the above works for acceptance (no confirmation by the IT Infrastructure Offices of the correctness of performance) results in charging the contractor at any time after the completion of works, in which ORLEN finds damage,
 - h) Damage to the existing telecommunications infrastructure of ORLEN S.A. during the work carried out is charged to the contractor.

Liquidation of the back-up facility, land or construction site handover

1. The contractor is obliged to liquidate the facilities and transfer the area (square) in the state specified by the contract or in the permit, after completion of the work and formal acceptance by the ordering party, unless the deadline is specified in the contract should be given in the acceptance report.
2. The Contractor shall, in the agreed scope, dismantle and liquidate the connections made for the site and submit them to the Department of Geodetic and Cartographic Documentation.
3. The Contractor obtains confirmation from the person in charge of the Geodetic and Cartographic Documentation Department or a person designated by him, about the cancellation of the reservation of the land for the back-up facilities.
4. The contractor returns the site in order on the basis of the REMOVAL OF THE BACK-UP FACILITY/TERRAIN/SITE/CONSTRUCTION form signed by both parties.

Social and living facilities

Social and living facilities located on the premises of a Production Facility in Płock, PTA Facility in Włocławek, CCGT Włocławek Facility or on areas adjacent to Contractors with contracts for the implementation of planned and technological repairs.

1. For the Contractor performing works under scheduled and technological repairs, the location of the social and living facilities is determined by the Technical Infrastructure Department.
2. It is required to conclude contracts with service providers and to cover their costs themselves, to use the media in the social and living facilities, i.e. :
 - a) electricity and other energy media,
 - b) drinking water, as indicated by meters installed at outflows or power supply,
 - c) export of solid and liquid waste,
 - d) sewage disposal.
3. The Contractor is obliged to notify 1 month before the renovation or within the time limit set by the Supervisor of the Ordering Party about the planned amount of setting his own containers:

	SAFETY STANDARDS	ORLEN S.A.
Version: January 2024	OCCUPATIONAL HEALTH AND SAFETY EXECUTIVE GUIDELINES FOR CONTRACTORS	Page no.: 68

- office,
 - social,
 - warehouse,
 - sanitary.
4. Containers must be technically functional, aesthetic and meet all social conditions - health and safety and fire protection.
 5. In order to ensure the order and aesthetics of the area of the production plant in Płock and areas to it. Adjacent Contractor having facilities, is obliged to independently maintain the cleanliness of the area.
 6. Social and living facilities of companies must be equipped with hand-held fire-extinguishing equipment in accordance with KSP, but not less than 1 unit of fire-fighting equipment for each barracks. Externally accessible fire-extinguishing devices must be provided - leaving adequate free space.
 7. Municipal wastes generated in connection with the works conducted by the Contractor's employees on the premises of ORLEN S.A. should be placed in containers intended for selective municipal waste collection. Containers other than municipal waste, in particular hazardous waste, may not be put into containers.

The transfer of construction sites

Transfer of construction sites at the Production Facility in Płock, PTA Facility in Włocławek, CCGT Włocławek Facility or areas adjacent to the Users or Land Owners for the implementation of renovation works and investment tasks from the 30000/40000 group.

- 1) The site (square) of construction should be transferred via protocol.
- 2) When transferring the construction site, ORLEN SA is represented by the commissioner of works, in cooperation with the industry supervision inspector. In the case of the construction industry - the construction supervision inspector of the leading industry.
- 3) Arrangements made when handing over the construction site for the purpose of performing works related to site preparation (e.g. tree felling, demolition and removal of existing facilities, equipment and site cleaning), or performance of other works included in the contract within the scope of implementation investment project.
- 4) The Ordering Party should provide the Contractor with the necessary documents, such as:
 - a) site plan of the area on an appropriate scale along with the current state of underground utilities and above-ground deposits,
 - b) list of established working benchmarks (if any),
 - c) a list of the ordinates of the existing terrain in the form of grid leveling results (if any),
 - d) a map attachment showing the border of the transferred area drawn in color on the map, agreed in the Geodetic and Cartographic Documentation Department and positively evaluated by the person managing the Spatial Information and Design Analysis Office or appointed by him,
 - e) agreeing on the consumption of energy media and all connections to the general plant networks in relation to the plan,
 - f) use of the roads shown on the plan for the needs of the Contractor,
 - g) permit to carry out works.
- 5) If necessary, the ordering party should prepare and provide the Contractor with other documents resulting from the situation.
- 6) The documents referred to above are prepared by the ordering party in consultation with the Geodetic and Cartographic Documentation Department and other interested organizational units of ORLEN S.A.
- 7) The contractor is responsible for the acquired site, including the facilities, until the completion of works and a formal return of the area with surroundings.

	SAFETY STANDARDS	ORLEN S.A.
Version: January 2024	OCCUPATIONAL HEALTH AND SAFETY EXECUTIVE GUIDELINES FOR CONTRACTORS	Page no.: 69

- 8) The given area (square) of construction should be fenced and have a yellow information board, on which all information about the investment, investor, emergency telephone numbers and telephone of the manager of a given construction must be posted.
- 9) On the transferred construction site communication routes should be paved, including access to social rooms, access routes for emergency services and storage yards.
- 10) It is strictly forbidden to create permanent landfills and places for storing any waste on the construction site and in its vicinity.
- 11) Waste generated in the construction process should be selectively stored, removed from the construction site and managed in accordance with the applicable provisions and provisions of the contract. Recommended removal cycle from the construction site is 7 calendar days.
- 12) The Contractor is responsible for the proper management of municipal waste generated on the acquired construction site, including the back-up facilities, and is obliged to ensure the collection of municipal waste on its own by signing a contract for the collection of selectively collected waste with an authorized company.
- 13) The Contractor's duties include the equipment of the back-up facility in a for municipal waste, and on the site of construction, designation and marking of a place for temporary storage of waste.
- 14) The Contractor is obliged to:
 - a) exercise general supervision over the conduct and compliance with the regulations as well as OSH and fire protection rules,
 - b) maintain cleanliness and order in the subordinate area,
 - c) comply with the conditions that should be met by the area or facilities,
 - d) organization and coordination of services;
 - e) protection of the construction site, back-up facilities and other elements of development located in the (site) area, unless they are foreseen for liquidation.
- 15) The Contractor, unless he proves that the damage is caused by a third party, shall be liable for damages on a risk basis resulting from acts or omissions in relation to the equipment and installations of ORLEN SA. located on the given territory - from the moment of its adoption, until the moment of formal return and resulting from agreements concluded between the parties.
- 16) Development of the site should be made in accordance with the documentation and detailed arrangements, which should include:
 - a) land development plan / square / construction and social and assembly facilities;
 - b) arrangements with the relevant services of ORLEN SA in the field of energy media consumption, electric power supply, etc .;
 - c) arrangements made with the ordering parties regarding the organization and conditions of carrying out works and the validity date of the back-up facilities location;
 - d) agreeing on the scope of disassembly works after completion of works on the site;
 - e) agreements regarding the arrangement of the area after the back-up facilities liquidation.
- 17) Depending on the situation and for the needs of a given site, the Contractor develops documentation containing i.a. place and methods of connection to the electrical, teletechnical and other networks located on the site - to the similar ORLEN SA networks, as well as the identification of collection points.
- 18) Handing over the Contractor's construction site for investment projects carried out by the Property Investment Implementation Office should take into account the requirements contained in the "Instructions for the preparation and implementation of property investment projects in ORLEN S.A."

Fixed back-up facilities

Conditions to be met by fixed facilities located on the premises of the Production Facility in Płock, PTA Facility in Włocławek, CCGT Włocławek Facility for Contractors with periodic, servicing and ongoing repairs.

	SAFETY STANDARDS	ORLEN S.A.
Version: January 2024	OCCUPATIONAL HEALTH AND SAFETY EXECUTIVE GUIDELINES FOR CONTRACTORS	Page no.: 70

1. Permanent back-up facilities may be located on the premises of the Production Facility in Płock, PTA Facility in Włocławek, CCGT Włocławek Facility or within them only and exclusively on the basis of a contract (lease, access) concluded between interested parties in accordance with the Company's real estate management principles set out in relevant internal regulations.
2. The application for leasing / renting / sharing facilities is made by the land owner supervising the property on which the facilities are to be located, to the Property Disposal Department, indicating its location and special conditions of use and special obligations of the lessee / tenant to be included in the contract in relation with the characteristics of his business or real estate status (on which the back-up facilities are to be located). The application should be accompanied by:
 - a) consent of the Control and Security Office (for the establishment of facilities on the premises of the plant for a given Contractor),
 - b) recommendation of the OHS Office (in the scope of occupational safety and health, fire protection and process safety),
 - c) recommendation of organizational units responsible for the implementation of contracts with Contractors and for the settlement of these contracts, confirming that the contractor applying for the lease performs the service for the Company, indicating the time of implementation and no objections to the cooperation with it so far,
 - d) a map with the boundaries of the subject of the lease/rent/share made available, developed by the Department of Geodetic and Cartographic Documentation and approved by the person managing the Office of Spatial Information and Design Analysis or appointed by him/her.
3. Agreements referred to in point 1 of this Chapter are prepared by the Department of Real Estate Disposal and are subject to acceptance by the Owners of leased / rented / shared areas in terms of safeguarding the legitimate interests of the Company, including the requirements for location and use of fixed facilities on terms similar to temporary facilities provided for this Instruction.
4. Agreements referred to in point 1 of this Chapter should contain a provision concerning the Contractor's liability for municipal waste management, including submission of the "DO-1 Declaration" in the relevant City Hall regarding the amount of the municipal waste management fee (Annexes No. 25-29).

24. Regulations regarding introduction for official use of the "Instructions for radiological protection at the premises of ORLEN S.A."
--

The National Atomic Energy Agency is the supervisory authority over nuclear safety and radiological protection. The GENERAL DIRECTOR of ORLEN S.A. is responsible for the state of radiological protection and nuclear safety in ORLEN S.A.. Internal supervision is carried by the RADIOLOGICAL SAFETY INSPECTOR (RSI).

Proper protection of radioactive sources is an essential component of its safety – if you have noticed an item marked with a clover in a place not intended for it - inform your supervisor. Do not approach the marked sources of radiation - minimize the time spent in the radiation field and use covers that will weaken or completely absorb radiation.

Entry and work of radiological teams on the premises of the production Production Facility in Płock and the PTA Facility in Włocławek shall take place taking into account the following principles:

- all work related to ionizing radiation, carried out by external Contractor, should be preceded by the approval of RSI, persons replacing RSI or authorized by him (during his absence) on a basis of a one-off permit for radiological examinations by radiographic teams with apparatus containing radioactive sources. Copies of the radiological permit should be attached to a one-off permit to perform particularly hazardous work issued for the facility,

	SAFETY STANDARDS	ORLEN S.A.
Version: January 2024	OCCUPATIONAL HEALTH AND SAFETY EXECUTIVE GUIDELINES FOR CONTRACTORS	Page no.: 71

- teams will enter the Production Facility in Płock exclusively through Gate No. 1, the premises of the Department of Research and Development Center by the road indicated by the service, the premises of the PTA Plant in Włocławek through the entry gate No. 1, the premises of the CCGT Plant through the main entrance gate,
- the security service, based on the issued permit and in accordance with the accepted procedure, regarding the issue of passes, let in the radiographers, confirming their entry and exit, and archiving an additional copy of the permit at the gate;
- during radiological examinations, a permanent ban on performing other works by other persons in the controlled area specified in the permit is obligatory,
- direct supervision over radiographic works is performed by the operator of this company, who has periodic health and safety training for the staff managing the employees, and the person responsible for the safety conditions is the RSI of the given company,
- if the absence of a designated controlled area and proper radiological supervision will be found, RSI calls the Security Service and in its presence orders the crew to stop the work and leave the site and requests the Control and Security Office to ban the crew from entering the Production Facility in Płock, the Department of the Research and Development Center or the PTA Facility in Włocławek. (Annex No. 29).
- each external Contractor conducting radiological examinations at the Production Facility in Płock is obliged to inform the Central Department of Scheduling and Production Coordination about this fact 15 minutes before the commencement of the works - call 24 256 50 11.

The external Contractors performing maintenance of isotope equipment are required to inform ORLEN SA' RSI about possible faults and to place an appropriate entry in the maintenance and technical service reports.

25. Regulation regarding the safety of loading and unloading of road tankers at the Fuel Terminals of ORLEN S.A.

The "Fuel Terminal Safety Card of ORLEN SA" - safety regulations for loading and unloading of road tankers at the Fuel Terminals of ORLEN SA, called the "Safety Card" is implemented for official use in ORLEN S.A.

The persons managing Fuel Terminals and employees subject to them are obliged to observe and enforce the rules of the "Safety Card" and to provide the "Safety Card" to all drivers of tankers collecting fuel at ORLEN SA

- Each person staying on the premises of the Fuel Terminal is required to comply with state and internal regulations and recommendations, and in the event of an alarm to comply with the instructions of the Fuel Terminal employee, including the Head of Rescue Operations (KDR).

For non-compliance with the provisions (instructions, "Safety Cards" and safety, fire and traffic regulations), the driver takes full responsibility and consequences, including the prohibition for entering the premises of the Fuel Terminal, inclusive. A speed limit of 20 km / h at the Fuel Terminals is valid. You should follow the vertical signs, horizontal signs, optical signals (lights) and the Fuel Terminal Service commands.

In the area of the Fuel Terminal it is prohibited to:

- perform any repairs of the tankers,
- use open fire,
- smoke outside the designated and marked places,
- use mobile phones excluding customer service rooms,
- take pictures and to film,

	SAFETY STANDARDS	ORLEN S.A.
Version: January 2024	OCCUPATIONAL HEALTH AND SAFETY EXECUTIVE GUIDELINES FOR CONTRACTORS	Page no.: 72

- use electronic devices made without the Ex standard,
- block roads and crossings, extinguishing equipment access routes and emergency exits,
- move on other than designated road,
- maneuver within entry and exit terminals as well as filling and unloading stands, without the help of a person outside the vehicle,
- drive with an open cover of the loading and unloading box,
- drive with opened upper hatch.

At the Fuel Terminal, tankers drivers are obliged to use protective anti-electrostatic clothing and footwear, gloves, safety goggles and protective helmets with CE certificate.

The tanker can be loaded only after performing the following actions: - switch off the engine and other devices with electric power supply, such as radio, heater, mobile phone, etc., apply the parking brake, set the earthing, the vapor system and anti-overfill system.

When filling the tank truck, the driver is forbidden to leave the filling station and the driver's cabin door should remain closed during loading.

In the event of any overfilling, spillage of fuel or other accidents, stop the filling / unloading immediately and report this fact to the Fuel Terminal staff.

Due to the damage caused by the driver, his employer - the perpetrator of the damage, may be charged with the costs resulting from removing the damage. The "Fuel Terminal Safety Card of ORLEN S.A." contains maps of all Fuel Terminals of ORLEN S.A.

26. Regulation on the implementation for business use of the "Fire and Chemical Safety Regulations of ORLEN S.A."

General organizational and ordering rules related to fire and chemical safety of ORLEN S.A. facilities.

- Fire Safety Instructions should always be available to employees (in paper or electronic form) and to the emergency services (in paper form).
- All ORLEN S.A. facilities must be provided with instructions on proceeding in the event of fire, chemical accident or other local emergency, including a list of emergency numbers, in a public place.
- All production and storage facilities, buildings and back-up facilities should be marked with a plate indicating the name of the facility / company and the person responsible for fire and chemical safety of the given facility, with a 24-hour/day contact telephone number. In fuel terminals outside Płock, such information should be placed in the porter's lodge, which is supervised 24/7 by the prevention.
- As a rule, the location of the assembly point for evacuation is the northeast corner of each plot.



- On the premises of ORLEN S.A. smoking cigarettes and alternative products are forbidden, except for properly arranged smoking rooms marked with the information "TU WOLNO PALIĆ" or "PALARNIA". In buildings where there is no technical possibility to create a smoking room, smoking cigarettes and alternative products are strictly forbidden. The smoking room should be equipped with mechanical exhaust ventilation or a filtration system preventing the

	SAFETY STANDARDS	ORLEN S.A.
Version: January 2024	OCCUPATIONAL HEALTH AND SAFETY EXECUTIVE GUIDELINES FOR CONTRACTORS	Page no.: 73

penetration of tobacco smoke to other rooms, handheld fire-fighting equipment and ashtray for extinguishing cigarette butts. If the smoking room is located in production, workshop or back-up facilities, it must be additionally equipped with a water container to extinguish cigarette butts.

- **It is allowed to:**

- organize permanent outdoor smoking rooms in the form of temporary construction facilities. Permanent outdoor smoking rooms must be made of non-flammable and non-fire spreading elements.
- organize temporary outdoor smoking rooms for employees of external companies for the duration of renovation/investment works on installations emptied of utilities, enclosed to a height of at least 0.5 m with a housing made of non-flammable material. It must be equipped with a water container to extinguish cigarette butts,
- organizing temporary outdoor smoking rooms for employees of external companies for the duration of renovation/investment works on installations in the form of a closed temporary cubature facility made of non-combustible materials. It must be equipped with a water container to extinguish cigarette butts,

Outdoor smoking rooms must be located at least 30 m from the designated explosion hazard zones and at least 10 m from cubature facilities. Sewerage chambers must be secured within a 20 m radius from the outdoor smoking room. Outdoor smoking rooms must be equipped with handheld firefighting equipment and ashtray to extinguish cigarette butts. It is recommended to create 1 temporary smoking room per 200 Contractor's employees. The smoking room should have an area of at least 10 m². The location of the smoking room should be indicated by the manager of the organizational unit and the Head of the Company Fire Brigade (for facilities located in Płock and Włocławek), and for facilities located outside Płock and Włocławek with an authorized employee of the ORLEN Eko Sp. z o.o.

- Social and assembly facilities of external enterprises located on the premises of production facilities should be organized in such a way as not to impede communication on internal roads and to prevent access to fire-fighting devices. Each facility and each temporary facility must be marked in such a way that the owner can be identified, and also with the person to contact (including the contact telephone number). The location of the facilities at the Production Plant in Płock must be agreed with the Commander of the Company Fire Brigade, and for the PTA and CCGT Plants in Włocławek, fuel terminals and other facilities located outside Płock and Włocławek – with an authorized employee of ORLEN Eko Sp. z o.o.
- It is forbidden to block entries to the installation area in a way preventing entry of rescue vehicles.
- Storage of technical gases at the Company's premises should be carried out in accordance with state regulations.
- Fire and chemical safety inspections at the Company's premises may be conducted by:
 - Employees of the Company Fire Brigade,
 - Employees of the Group OHS and Prevention Coordination Department,
 - Employees of ORLEN Eko Sp. z o.o. in accordance with the scope of contracts.
- Ad hoc inspections of the state of fire and chemical safety can be carried out by Managers of facilities in their area. As part of patrol activities, security service employees have the right to check whether the fire and chemical safety rules are enforced in the Company's facilities and companies conducting work at ORLEN S.A. Security officers immediately inform the Commander of the Company Fire Brigade about all irregularities found in the field of fire and chemical safety. In disputes regarding the controls of fire and chemical safety, you can appeal to the Head of the Occupational Health and Safety.

	<p style="text-align: center;">SAFETY STANDARDS</p>	<p style="text-align: center;">ORLEN S.A.</p>
<p>Version: January 2024</p>	<p style="text-align: center;">OCCUPATIONAL HEALTH AND SAFETY EXECUTIVE GUIDELINES FOR CONTRACTORS</p>	<p style="text-align: center;">Page no.: 74</p>

When performing fire hazardous works, you need to:

- protect combustible materials against fire, occurring in the place of work and in adjacent areas, including elements of the structure of the object, and related technical installations;
- secure drains within a minimum radius of 20 m;
- carry out fire-hazardous works in potentially explosive atmospheres or in spaces where other work has previously been carried out related to the use of flammable liquids or flammable gases, only if the concentration of the vapors of liquids or gases in the mixture with air at the place of work does not exceed 10% of their lower explosion limit;
- have at the place of work equipment enabling the elimination of all sources of fire;
- organize and control the place where the works were carried out and in the adjacent areas;
- provide technically efficient equipment designed to carry out work in accordance with the principles of health and safety and fire safety.
- during work, use extreme caution, eliminate the potential of the source of fire and the observed sources of fire, and in the event of a situation threatening with fire, chemical failure or other local threat stop working.
- It is the duty of the person carrying out fire-hazardous works to comply strictly with the conditions set out in the written permit.
- All employees of external entities conducting work at ORLEN S.A. are required to acknowledge and comply with the provisions on fire and chemical safety in force at the Company's premises.

Procedures and rules on acceptance of fire protection documentation:

- Commencement of use for new, rebuilt, renovated, modernized facilities and after a change in the way of its use follows commissioning activities in accordance with the applicable regulation,
- In order to collect the object in terms of fire protection, the investor must provide the Company Fire Brigade with full technical documentation regarding fire protection at least 7 days before the planned acceptance,
- The Company Fire Brigade performs the acceptance of facilities in terms of fire protection in the form of a local vision in accordance with the provided technical documentation,
- The Company Fire Brigade should be informed each time about the planned deadlines for the implementation of activities related to the commissioning or technical tests of safety and fire protection installations in order to participate in these activities.,
- The Company Fire Brigade, when performing acceptance activities, has the right to request the activation of selected safety and fire protection installations.

Rules for alerting and informing people and services

Every employee who has noticed a fire, chemical accident or other local threat is absolutely obliged to warn people nearby as well as notify their superiors and alert:

- Company Fire Brigade - in the case of facilities at the Production Plant in Płock or other appropriate fire protection unit,
- Company Fire Brigade of ANWIL S.A. – at the PTA and CCGT Facilities in Włocławek,
- the nearest local unit of the State Fire Service (for other facilities outside Płock and Włocławek) by calling the telephone numbers:

19 998 – Company Emergency Number in Płock

19 998 – PTA and CCGT Facilities in Włocławek

998 or 112 – The State Fire Service throughout the country.



	<p style="text-align: center;">SAFETY STANDARDS</p>	<p style="text-align: center;">ORLEN S.A.</p>
<p>Version: January 2024</p>	<p style="text-align: center;">OCCUPATIONAL HEALTH AND SAFETY EXECUTIVE GUIDELINES FOR CONTRACTORS</p>	<p style="text-align: center;">Page no.: 75</p>

The emergency report should be short, concise and clearly define:

- place of fire, chemical failure or other thread,
- existence of danger to people,
- type of released substance,
- name and phone number from which you are calling;
- other data allowing a proper decision on the disposition of forces and resources by the person receiving the notification.

Announcement of chemical alarms

Production Facility in Płock

In the event of a chemical accident hazard, a chemical alarm in one of three phases is announced:

Phase "I" alarm - it is announced when the hazard range covers the installation node or installations, not exceeding the boundary plot - main roads. The alarm is announced by an alarm siren or buzzer, with **modulated sound signals lasting 3 minutes**.

Phase „I” alarm is announced by the facility manager or a person authorized by him (e.g. Shift Supervisor). If a large amount of hazardous substances suddenly escapes (e.g. hydrogen sulfide, liquefied gas), any employee who notices this occurrence may issue an alarm.

Phase "II" alarm – it is announced when the threat exceeds the area of one plot or one installation. The **phase "II" alarm** is announced by repeating the **phase "I" alarm** sound signals by alarm sirens from several or all facilities at the Production Plant in Płock. The decision to announce the phase "II" alarm is made by the Head of the Rescue Operation (KAR) or the Head of Rescue Activities (KDR) in consultation with the Central Production Scheduling and Coordination Department.

At the same time, information about the announcement of the **phase "II" alarm** is transmitted via the Warning and Alarm System messages.

Phase "III" alarm – the phase „III” chemical alarm is a continuation of the **phase "II" alarm** and it is a consequence of the development of the action outside the fencing area of the Production Plant in Płock. The activities are carried out on the basis of the External Emergency Plan. The decision to announce the phase "II" alarm is made by the Head of Rescue Activities (KDR) in consultation with the Central Production Scheduling and Coordination Department.

PTA and CCGT Facilities in Włocławek

In the event of a chemical accident at the premises of PTA and CCGT Facilities in Włocławek, the following chemical alarms are issued depending on the scope and direction of the threat.:

- 1st degree chemical alarm
- chemical alarm - warning
- 2nd degree chemical alarm
- 3rd degree chemical alarm

	SAFETY STANDARDS	ORLEN S.A.
Version: January 2024	OCCUPATIONAL HEALTH AND SAFETY EXECUTIVE GUIDELINES FOR CONTRACTORS	Page no.: 76

1st degree chemical alarm

The 1st degree chemical alarm is announced in the event of a local chemical threat on the premises of the PTA or CCGT Facilities in Włocławek, which does not threaten the areas adjacent to the plant. The alarm is announced by means of a horn with intermittent sound signals lasting 2 sec. with breaks of 1 sec. Total signal transmission time is 3 minutes. The 1st degree chemical alarm is announced by the head of the PTA Plant or the CCGT Włocławek Plant or a person authorized by him (e.g. Shift Supervisor). In addition, a light signal is generated.

Cancellation of the 1st degree chemical alarm is done by a verbal signal (voice announcement). The 1st degree chemical alarm is canceled by the head of the PTA Plant or the CCGT Włocławek Plant or a person authorized by him (e.g. Shift Supervisor).

Chemical alarm - warning

Chemical alarm - warning is used to alert employees about occurrences on the premises of the PTA Plant, CCGT Włocławek Plant or ANWIL S.A. of a threat not threatening the areas adjacent to the plant. Chemical alarm - warning is announced by the Company Dispatcher at ANWIL S.A. The verbal signal is accompanied by a continuous acoustic signal lasting 1 minute. Chemical alarm - warning is dismissed by the Company Dispatcher at ANWIL S.A. through an appropriate message.

2nd degree chemical alarm

The 2nd degree chemical alarm is announced in the event of a local chemical threat at the premises of PTA or CCGT Włocławek with the possibility of extension to ANWIL S.A. production installations or Indorama Ventures Poland Sp. z o.o. The alarm is announced by means of an intermittent acoustic signal (modulated) of sirens lasting 3 minutes and the transmission of an appropriate message by the Company Dispatcher at ANWIL S.A.

3rd degree chemical alarm

The 3rd degree chemical alarm is a continuation of the 2nd degree alarm and is a consequence of the development of the action outside the fence of the PTA Plant. The 3rd degree chemical alarm is announced by the Company Dispatcher at ANWIL S.A. The light signal is accompanied by an intermittent acoustic signal (modulated) of sirens lasting 3 minutes. Additionally (depending on the wind direction) the "stop" traffic lights can be turned on on the roads:

- national no 1,
- local Krzywa Góra-Gąbinek,
- local Włocławek – Brzezcie.

Cancellation of the 2nd and 3rd degree chemical alarm is done by a continuous acoustic signal of sirens lasting 3 minutes and an appropriate message issued by the Company Dispatcher at ANWIL S.A.

Handheld fire-fighting equipment:

All facilities should be equipped with handheld fire-fighting equipment adapted to extinguishing these groups of fires that may occur in the facility. At the ORLEN S.A. the basic unit of mass of extinguishing agent is 6 kg (in the case of powder extinguishers) or 5 kg (for snow extinguishers).

	SAFETY STANDARDS	ORLEN S.A.
Version: January 2024	OCCUPATIONAL HEALTH AND SAFETY EXECUTIVE GUIDELINES FOR CONTRACTORS	Page no.: 77

27. Operational regulation regarding security posts at the Production Facility in Płock and the PTA Facility in Włocławek.

On the premises of the Production Facility in Płock, the security posts are set up by the Company Fire Brigade and they include protection during works with fire hazards, chemical hazards, underwater operations and works during maintenance, emergency stoppages, plant start-ups, if it is required for the safety of the works carried out.

Security posts at the CCGT and PTA Facility in Włocławek are carried out under a separate agreement concluded with the Company Fire Brigade of Anwil S.A. Włocławek.

Security posts on the premises of the Concern companies and external entities at the Production Facility in Płock are issued under concluded agreements and applications from these entities.

The need to issue a security post at the Production Facility in Płock is reported to the Company Fire Brigade (RBP) (tel. 24-365-70-32 or 33 or tel. IP 24-256-93-56).

The Company Fire Brigade is obliged to provide security posts for all working shifts, in a 24-hours per day system.

28. Regulation on the use of fire water network and marking and maintenance of hydrants at the Production Facility in Płock.

For activities related to checking, maintenance, functional tests of water sprinkling installations as well as organization of tactical and combat exercises (maneuvers), a fire water network is used.

The unreconciled collection of water from the main fire network and internal fire water networks installed on production installations and the use of equipment installed on them for purposes not related to fire protection is prohibited.

In exceptional and justified cases, it is allowed to periodically use the fire water network for purposes not related to fire protection, based on the written permission obtained for the collection of fire water.

A written application for permission to collect fire water for purposes not related to fire protection is submitted to the manager the Water Production Unit (SWP) in the Water & Wastewater Plant (PWS) or a person authorized by it:

- for the needs of the organizational units of ORLEN S.A. – the manager of the interested organizational unit or a person authorized by him,
- for the needs of other recipients - a person authorized on behalf of the company, etc.

A written permit for the collection of fire water is issued by the manager of the Water Production Unit (SWP) in the Water & Wastewater Plant (PWS) or a person authorized by it. The obligation to use pressure reducers for water intake from the fire water network comes into force in February 2022.

The Issuer of the above mentioned permit shall send information in this matter by e-mail to:

- Company Fire Brigade,
- Wastewater Unit.

Permission for temporary, short-term use of the fire water network by the organizational units of ORLEN SA can be issued by the the manager the Water Production Unit (SWP) or a authorized person authorized by him – on working days, while during his absence (non-working days, 2nd shift) - Master of Production Processes - Shift manager of the Water Production Unit, after informing about the fact the Company Fire Brigade.

 ORLEN	SAFETY STANDARDS	ORLEN S.A.
Version: January 2024	OCCUPATIONAL HEALTH AND SAFETY EXECUTIVE GUIDELINES FOR CONTRACTORS	Page no.: 78

For activities related to checking, maintenance, functional tests of water sprinkling installations and semi-permanent foam fire-extinguishing systems as well as organization of tactical and combat exercises (maneuvers), a fire water network is used and in the case of rinsing the intra-plot network, it is required to obtain approval from the Master of Production Processes - Shift manager of the Water Production Unit and Wastewater Unit).

Immediate interruption of fire water intake for purposes not related to rescue and extinguishing operations takes place in the case of the necessity of carrying out rescue and firefighting operations.

The following are authorized to make a decision to immediately stop the collection of fire water:

- Manager of the Water Production Unit (SWP) in the Water & Wastewater Plant (PWS) or a person authorized by him,
- person managing the Water & Wastewater Plant (PWS),
- Master of Production Processes - Shift manager of the Water Production Unit (non-working days, 2nd shift),
- Head of Company Fire Brigade or a person authorized by him,
- Shift dispatcher of the Water and Wasteland Plant,
- Manager of the organizational unit, in which there is a fire water intake point.

Persons issuing permits for the collection of fire water and the Company Fire Brigade are obliged to immediately issue a ban on collecting fire water from the network in the event of non-compliance with the permit or arbitrary collection by the user.

Outdoor hydrants should be marked in accordance with the applicable legal regulations in accordance with PN-97 / N-01256/04, item 220. The marking applies to both hydrants belonging to the main network and to the intra-plot network. Consultation on the correct marking of hydrants is provided by the Water & Wastewater Plant (PWS).

Example of written permission for water collection is provided in Annex no. 32.

29. Additional guidelines clarifying the rules of ordering, commissioning and carrying out works using mobile cranes and lifts, ie lifting devices mounted on vehicles, on the premises of the Production Facility in Płock, PTA and CCGT Facility in Włocławek and the Fuel Terminals.

In order to ensure safety for people as well as for infrastructure that is used in accordance with the law.

1. The Contractor has knowledge of the exact mass and position of the device being transported, in order to select the equipment for work by the Contractor.
2. Select the place where the transport device is located, eg cable routes, sewerage, sloping ducts, teletechnical wells, etc. In this case, when they are available and equipped with transport equipment in the workplace and during its approval.
3. Work in collision conditions of these devices. If it is not possible to avoid collision work, the Contractor should draw up an Hoisting Plan and develop a Safety Instructions for transport work.
 - The Lifting Plan should include:
 - device data: weight of auxiliary equipment, weight of the rigging, total weight of the device, lifting height, working area of the device with additional equipment, center of gravity position.
 - equipment data: manufacturer, model, size, length of the jib, length of the boom block, dimensions of the load being lifted.

	SAFETY STANDARDS	ORLEN S.A.
Version: January 2024	OCCUPATIONAL HEALTH AND SAFETY EXECUTIVE GUIDELINES FOR CONTRACTORS	Page no.: 79

- rigging data: sling parameters, length, suspension construction, permissible working load, hook type, size and load capacity of connecting elements.
- capacity calculation: boom length, lifting angle, lifting capacity, boom foot size, permissible wind speed, assumed ground stability and inclination,
- proximity of overhead power lines, load-bearing overpasses of pipelines, mulds, apparatuses
- local threats and the way they are controlled: including the crane's track, ground stability, proximity of people or equipment and the agreed manner of communication,
 - when the crane is equipped with a device that measures the weight of the load being lifted, the operator should be able to read the actual weight of the load from the display.
- Safety instructions for transport work are common for all collision equipment working in collision work.

This manual should contain:

- guidelines for the organization of transport work in the area of crane work, taking into account the conditions prevailing at the place of transport,
- tasks and responsibilities of persons involved in transport work,
- characteristics of the materials or objects being moved,
- coordination of activities and safety of all persons who may be exposed to hazards resulting from carrying out transport work carried out in a collision,
- a joint work coordinator for all devices working in collision conditions should be appointed. The coordinator should be a person with signaling rights, while the method of communication with operators should be described in the safety instructions for transport work,
- a way to deal with a failure should be developed.

4. The work of lifting devices taking place above active (or filled with hydrocarbons) overpasses, mulds, and braces should also be considered as working in collision conditions.
5. Due to the size and complexity of the infrastructure of production installations, limited field of view of operators / drivers of mobile crane, crane or other lifting equipment, entry and work in confined spaces, it is recommended to treat entry into the installation as a process of increased risk therefore, a whistleblower should be ensured. The designation of such a person belongs to a company using the services of a transport device. Movement should be understood as access to the final place of installation, departure from this place and operation of moving the device in conditions of limited space.
The requirement to provide a signaller to secure the displacement of the device should be planned at the stage of commissioning work or at the request of the issuer of the permit.
6. The work contractor should operate the mobile crane in accordance with the minimum requirements specified below:
 - The device operator is required to make an initial assessment of the device's performance before starting work on each change. The assessment of the technical condition of the device should be documented and stored on the device. Details of the initial fitness assessment must be based on the appropriate hazards corresponding to the device in question.
 - A self-propelled crane must have nominal lift capacity tables, located in a place visible to the crane operator and available in the cabin,
 - The operator's control position for cranes mounted on vehicles must be located in the area protected from movements of the load being lifted and the boom.
 - Rotating parts must be immobilized while the crane is moving.
 - The operator must wear seat belts,

	SAFETY STANDARDS	ORLEN S.A.
Version: January 2024	OCCUPATIONAL HEALTH AND SAFETY EXECUTIVE GUIDELINES FOR CONTRACTORS	Page no.: 80

- The use of crane supports is obligatory (supports are to be extended as low as possible and spread as wide as possible) unless otherwise specified in the hazard assessment,
- The boom rotation test must be carried out before starting lifting,
- The operator can not leave the crane with a suspended load.

Each lifting vehicle and every other vehicle over 3.5 tons must have a reversing sound sensor.

30. Safe work conditions on the installations renovation site.

1. Any work performed by external entities on the premises of ORLEN may only be performed on the basis of a work permit or IBRP instruction, provided that a signed contract and order are in place.
2. The contract for a given Company includes the scope of works covered by the contract and the names of the companies reported as a Subcontractor.
3. If after signing the contract, the Contractor wants to outsource part of the work to a Subcontractor, then he must obtain the consent of the Purchasing Office for subcontracting (the Purchasing Office and the Purchaser verify the Subcontractor).
4. After signing the contract, the employees reported for the contract by the Contractor should be verified in terms of their qualifications and knowledge by the ORLEN Training Center.
5. Employees reported for the performance of the contract who do not have a personal pass must be directed to information training on threats to safety and health and fire protection for employees of external companies performing work on the premises of ORLEN (training valid for 1 year). Information trainings are conducted at the ORLEN Training Center or at the ORLEN OHS Office.
6. Prior to the commencement of repair works, the Contractor's employees also undergo information training on local hazards that may occur in the renovated facility.
7. The Contractor provides the User with lists of names of employees trained for the performance of works.
8. The Manager of the Renovation Project, an employee of the Maintenance Services (the person managing the Renovation Complex or a person designated by him) responsible for running the Renovation Project, is obliged to submit to the Group OHS and Prevention Coordination Department and ORLEN Eko a list of concluded contracts in all industries for which scopes of work were developed during the overhaul / technological shutdown and works are planned for implementation. The list should be sent no later than 14 days before the planned date of renovation.
9. The list of Contractors should contain contact details to the Contractor's OHS Service and the number of people reported for the performance of the contract.
10. The list of Contractors, in the case of subcontracting by the company, should include the names of all Subcontractors and the number of people reported for the performance of the contract.
11. The Contractor is responsible for the safety of Subcontractors submitted for the performance of the contract.
12. The contractor analyzes and approves the IBWR developed by the Subcontractor, which he then submits along with the declaration to the ORLEN Eko's OHS Supervision.
13. OHS supervision of ORLEN Eko sends, if necessary, to the Group OHS and Prevention Coordination Department, a set of prepared and submitted IBWR documents and declarations in connection with the renovation.
14. The Contractor is responsible for training for Subcontractors and the necessary documents for ORLEN Eko to produce inserts with the name of the installation and the current year.
15. The Contractor and the Subcontractor familiarize their employees with the content of IBWR and have access to its content during the execution of works.

	SAFETY STANDARDS	ORLEN S.A.
Version: January 2024	OCCUPATIONAL HEALTH AND SAFETY EXECUTIVE GUIDELINES FOR CONTRACTORS	Page no.: 81

16. The contractor ensures supervision of the OHS service during the execution of works on the premises of ORLEN (for particularly dangerous works, min. of 1 person per 50 employees and for other works – min. 1 person) on the premises of the renovated facility during the execution of works.
17. The Contractor is responsible for ensuring the supervision of the OHS service by Subcontractors in accordance with the accepted standards (for particularly dangerous works, min. of 1 person per 50 employees and for other works – min. 1 person).
18. Companies participating in the works during the renovation / technological shutdown are required to sign the Agreement on the selection of the OHS Coordinator.
19. The OHS Coordinator is appointed (name/surname) by the company that will carry out the largest scope of work during the renovation / technological shutdown.
20. The Contractor's OHS Service is obliged to organize once a week an OHS meetings for the OHS service of the Subcontractors in order to discuss key safety-related operations carried out in the next week and health and safety irregularities identified during the event.
21. The Contractor's OHS Service draws up notes on the daily OHS inspections during the renovation.
22. Notes from the daily OHS inspections of the Contractor's OHS service should contain information on the safety of Subcontractors.
23. Notes on daily OHS inspections are sent by the Contractor's OHS service to the OHS Coordinator.
24. During the execution of works on the installation it is necessary to:
 - a. in the case of removing heavy elements from a densely built-up installation, where it is not possible to use mechanized equipment (cranes, forklifts, lifts, etc.), use handcarts with an appropriate structure and strength adapted to the transported elements,
 - b. bolts and nuts disassembled from repaired apparatuses, after cleaning and lubrication (in accordance with the technology indicated by the Technical Office), store in containers. Containers should be marked with the number of the device and protected against precipitation (tight closure or, for example, stretch foil).
25. The OHS Coordinator organizes daily safety walks with the participation of the Contractor's OHS service and OHS supervision from ORLEN Eko (if additional supervision is ordered by the User) and prepares notes on daily safety walks on the renovated installation. Notes are sent to the area OHS specialist in the Group OHS and Prevention Coordination Department.
26. The OHS Coordinator organizes safety walks at least once a week with the supervision of the Main Contractors, SUR and the User. The note from the safety walk is sent to the area OHS specialist in the Group OHS and Prevention Coordination Department.
27. ORLEN Eko organizes introductory / pre-renovation training on the safe conduct of renovation works for the supervision and OHS service of Contractors / Subcontractors.
28. In the case of the implementation of works related to the investment task during the maintenance / technological shutdown, safety walks conducted by the OHS Coordinator are performed by the Contractor's OHS Service and the ORLEN Eko's OHS Supervision (regarding orders by the Investor). The Contractor carrying out the investment task on the renovated installation shall be bound by the same requirements as for renovation Contractors.
29. During the maintenance shutdown, after the introduction of the renovation mode, a long-term permit for investment works may be issued subject to the approval of the Process Safety Committee, then the Contractor is obliged to develop, implement and conduct a documented system for carrying out particularly hazardous works in accordance with the regulations of ORLEN.
30. An example of a documented system for carrying out particularly hazardous works is included in Annex 39.

	<p style="text-align: center;">SAFETY STANDARDS</p>	<p style="text-align: center;">ORLEN S.A.</p>
<p>Version: January 2024</p>	<p style="text-align: center;">OCCUPATIONAL HEALTH AND SAFETY EXECUTIVE GUIDELINES FOR CONTRACTORS</p>	<p style="text-align: center;">Page no.: 82</p>

31. Additional guidelines regarding the EXCAVATION CONTROL CARD, places and methods of marking excavations during works carried out at the Production Facility in Płock

1. In order to ensure increased safety for the employees of Contractors and employees of ORLEN SA, the EXCAVATION CONTROL CARD is introduced, constituting Annex no. 40.
2. The EXCAVATION CONTROL CARD must be drawn up by the Site Manager of the Contractor performing the excavation or a person authorized by him.
3. Each excavation must be subject to a mandatory periodic inspection (at least every 10 days), and the information about the inspection must be recorded in p.VI of the EXCAVATION CONTROL CARD.
4. In the event of a change in the operating conditions of the excavation and its immediate surroundings (other earthworks carried out in the immediate vicinity of the excavation, additional means of transport in the vicinity of the excavation, changing weather conditions, etc.) the Site Manager of the Contractor performing the excavation must re-inspect the excavation confirmed by the issuance of the EXCAVATION CONTROL CARD.
5. After the excavation is completed and left for further works (e.g. for other contractors, maintenance activities for ORLEN SA employees, etc.), the Site Manager of the Contractor performing the excavation is obliged to inform these users about the actions taken in the field of safe use of the excavation (type of excavation, communication to- and from- the excavation, method of securing the walls of the excavation, required collective and individual protection measures, etc.) contained in the Annex.
6. If there are additional circumstances that require supplementing the content of the EXCAVATION CONTROL CARD, the Site Manager of the Contractor performing the excavation is obliged to complete them in the item: "OTHER".
7. The EXCAVATION CONTROL CARD must be legibly filled, protected against weather conditions and permanently attached to all stairs, ladders or other places serving as a descent to the excavation. In the absence of descents - the EXCAVATION CONTROL CARD should be placed on the fencing of the excavation in places designated as communication routes to the excavation zone.
8. **In the event of failure to meet the safety conditions during work in the excavation, the ,the Site Manager of the Contractor performing the excavation is obliged to place in the places specified in p.7 information on the prohibition of using the excavation. The EXCAVATION CONTROL CARD must then be removed and archived for a period of at least 6 months from the end of the works in this excavation.**
9. After completion of the earthworks and backfilling the excavation, the EXCAVATION CONTROL CARD should be removed.

32. Additional guidelines for the supervision of the construction and operation of scaffolding during works at the Production Facility in Płock, CCGT Włocławek and PTA Facility in Włocławek.

Each Contractor should be obliged to apply and comply with the following guidelines in the field of meeting the safety conditions for the assembly, reconstruction and disassembly of scaffolding, and the method of supervising their construction, operation and disassembly. The presented guidelines supplement the generally applicable regulations and do not limit their application in any way.

	SAFETY STANDARDS	ORLEN S.A.
Version: January 2024	OCCUPATIONAL HEALTH AND SAFETY EXECUTIVE GUIDELINES FOR CONTRACTORS	Page no.: 83

1. Definitions:

General Renovation Contractor – a company that performs renovation or modernization works on the premises of or for ORLEN S.A. and having a agreement signed directly with ORLEN S.A. and carrying out the major part of the renovation project.

Instructions for Safe Performance of Works (IBWR) – instructions specifying how to prevent risks related to the performance of construction works and the procedure to be followed in the event of these risks. The necessity to prepare IBWR results from the provisions of the Construction Law or conclusions from the JSA – Job Safety Analysis). Instructions for Safe Performance of Works (IBWR) should be prepared on the basis of the JSA and the detailed design for specific tasks.

Site Manager (Works Manager) – a person discharging the duties specified in art. 22 of the Act of July 7, 1994 – Construction Law.

Scaffolding - temporary structure, necessary for safety during work in assembly, maintaining, repairing or disassembly of buildings and other structures, ensuring easy access to these facilities.

Scaffolding construction and operation supervision specialist - a person supervising the works related to the construction of scaffoldings, as well as their use, appointed or authorized (in the investment process) by the Site Manager or by the Main Renovation Contractor from the mechanical industry (in the renovation process), hereinafter referred to as the Specialist, who meets at least one of the permissions listed below:

- has valid building qualifications/ certification in the construction and building industry,
- completed a scaffolding construction and operation specialist course conducted by the Polish Chamber of Commerce for Scaffolding or another organization appropriate for a given country, granting authorizations to assembly, commission and supervise the technical condition of scaffolding;
- has the state qualifications of a scaffolding Assembler issued by the "Institute of Mechanization of Construction and Rock Mining - Łukasiewicz Research Network" (for organizations located in Poland);
- has the relevant industry qualifications acquired in another country and certified by a competent examination unit,

For each of the above cases, it is recommended that the Specialist has professional experience in working in the scaffolding industry.

2. In the investment process, the Specialist is appointed by the Site Manager. It is allowed for this function to be performed by the Site Manager with valid building qualifications in the construction and building industry.

3. In the renovation process, the Specialist is appointed by the Main Renovation Contractor, i.e. the Company with the largest scope of works in the mechanical industry.

4. In the investment process, the Specialist reports directly to the Site Manager, in the case of renovation - to the OHS Coordinator, supervising occupational health and safety, selected from among all renovation contractors (in accordance with Article 208 of the Labor Code).

5. The Specialist is responsible for:

- arrangements with designated employees of a given Installation regarding the location of the scaffolding for the purpose of:
 - ensuring access to devices, fittings and communication routes,
 - safe construction, conversion and dismantling of the scaffolding,

the above arrangements are provided in the form agreed by the parties and archived until the completion of the task;

- contact with the Site Manager or the OHS Coordinator of the renovation of a given Installation;
- in order to provide information that has a fundamental impact on safety, scaffolding operation, including improper scaffolding foundation, incomplete scaffolding

	SAFETY STANDARDS	ORLEN S.A.
Version: January 2024	OCCUPATIONAL HEALTH AND SAFETY EXECUTIVE GUIDELINES FOR CONTRACTORS	Page no.: 84

elements (including passageways), lack of grounding or anchoring, the need to modify the scaffolding, conduct additional ad hoc scaffolding inspections, etc.;

- constant contact with the scaffolding contractor indicated in the scaffolding acceptance protocol in order to submit technical comments, the need to rebuild the scaffolding, remove it or perform a decade inspection, as well as other required actions resulting from state regulations in the field of scaffolding operation;
- coordination of the activities of companies assembling and maintaining scaffolding in terms of assembly, reconstruction, maintenance or disassembly of the scaffolding;
- ongoing control of compliance with safety regulations in the scope of scaffolding use by companies working on the scaffolding (e.g. checking the personal protective equipment used, the correct use of the scaffolding, tidiness, safety of third parties, etc.).

6. The Specialist is obliged to suspend the work carried out by employees (including other companies) in the event of irregularities in the completeness of the scaffolding, changing weather conditions, collisions with other Contractors working in the vicinity (including those carrying out work posing a threat to the environment), working heavy equipment, and in any other, undescribed dangerous situation that may contribute to the occurrence of a potentially accidental situation.

7. After the formal acceptance of the scaffolding admitted for use by the acceptance commission, specified in state regulations, the Specialist checks each scaffolding according to the Checklist from the scaffold inspection indicated in **Annex no. 41**. One copy of the Checklist is handed over to the Site Manager - in the investment process or to the OHS coordinator - in the renovation process. The second copy is archived until the end of this task.

8. A Specialist may be a member of the technical acceptance commission that hand over the scaffolding for use.

9. Types of scaffolding inspections performed by a Specialist:

- prior to the first use of the scaffolding;
- periodically (at least every 10 days);
- ad hoc:
 - after a break in the scaffolding operation longer than 10 days,
 - after the occurrence of unfavorable weather conditions that may affect the stability of the structure or its usability,

after changes in the position of the scaffolding, modification of the scaffolding structure (e.g. interruption of the continuity of barriers or passageways, other works ordered on an "ad hoc" basis).

10. Scaffolding register.

- Each scaffolding (including mobile scaffolding) must be registered by the scaffolding company in the scaffolding register kept for its scope of work. The scaffolding register must be forwarded to the Specialist and:
 - Site Manager - in the investment process;
 - OHS Coordinator of the renovation - in the renovation process and, at the same time, constantly updated. No scaffolding may be released for use before it is added in the scaffolding register.

11. The Specialist keeps a collective scaffolding register for a given investment or renovation process.

A typical scaffold register must contain the following minimum information:

- the company commissioning the assembly;
- the person responsible on the part of the Customer;
- the person collecting the scaffolding by protocol;
- the person responsible for the assembly of the scaffolding with a contact telephone number;

 ORLEN	SAFETY STANDARDS	ORLEN S.A.
Version: January 2024	OCCUPATIONAL HEALTH AND SAFETY EXECUTIVE GUIDELINES FOR CONTRACTORS	Page no.: 85

- a person using the scaffolding with a contact telephone number;
- scaffolding system;
- scaffolding area or volume;
- place of assembly and scaffolding number;
- assembly date;
- scaffolding acceptance protocol number.

33. Additional guidelines regarding use of electrical equipment: construction switchboards, extension cords, power generation sets and others

Each Contractor shall be required to use and comply with the guidelines prepared below in scope of meeting safety conditions during the execution of the work and/or on their premises, having in possession and operating electrical equipment (construction switchboards, extension cords, power generation sets).

DEFINITIONS

Safety - as used in this document, the term includes all aspects of personal safety including occupational health and safety and fire prevention, as well as process safety.

Contractor Safety Method Statement (IBWR) – an instruction of how the contractor shall perform their works safely, declaring ways of preventing hazards related to construction works and ways to act in case of emergence of those hazards. The obligation to write IBWR results from legislation of Prawo Budowlane (Construction Law) or results of JSA. IBWR must be drafted on the basis of JSA and the execution project for specific, branch tasks. Developed emergency scenarios must be included in the IBWR/BIOZ/IBRP/permit to work. IBWR must be opinioned in the Occupational Health and Safety Office & Group OHS and Prevention Coordination Department or ORLEN Eko Sp. z o.o. as per process in ORLEN S.A. for this scope.

Portable pass-through switchgears (MRP); Portable measurement systems (MUP) – are 3-phase switchgears (ORLEN owned) that are used for connection and billing in the construction switchboard (RB) balancing system for external recipients, that draw power for the purpose of executing assignments from ORLEN at the Production Facility in Płock

Power Extension cord – power cable section used to extend the reach of the wire between the electrical outlet and the device that draws electricity.

Construction switchboard – is an electrical switchgear used for temporary powering electrical installations. Additionally, it protects these installations from repercussions in the event of power overloads and short circuits.

Power generating set - is an autonomous unit for generating electricity.

ELECTRICAL EQUIPMENT REQUIREMENTS

Construction switchboards

Construction switchboards, due to their mobility are classified into groups:

- transportable (semi-permanent) – the place of setup can change while working in the same area (before changing the place, power must be first disconnected),
- portable – the place of setup can be changed while working in the same area without disconnecting the power.

 ORLEN	SAFETY STANDARDS	ORLEN S.A.
Version: January 2024	OCCUPATIONAL HEALTH AND SAFETY EXECUTIVE GUIDELINES FOR CONTRACTORS	Page no.: 86

When using portable switchboards (dubbed construction RBT's), the switchgear should be equipped with a 63A plug (in line with ORLEN S.A. standard) and powered by appropriately selected rubber-insulated cable, the cable should be protected from mechanical damage (especially on roads). A switchgear should be equipped with overcurrent and residual-current protection with a residual current of 30mA. After the switchgear is connected, measurements should be taken (electric-shock protection effectiveness, grounding and insulation resistance, action time and current of differential current protection tripping), the protocol of said measurements is valid for the entire renovation period. These measurements should be repeated after connecting the RB to another set of renovation outlets (relocation of RB).

ID nameplate.

The manufacturer of the construction switchboard places on the unit, in a prominent place, an ID nameplate (or plates) containing at least the following information:

- the name or factory marking of the units manufacturer (may be placed on the unit case);
- type designation, identification number, or other means of identification, allowing to obtain relevant information about the product from the unit's manufacturer;
- marking to identify the date of production;
- PN-EN 61439-4:2013-066;
- Type of current and frequency, in the case of alternating current (fn);
- ACS rated voltage of the unit (Un);
- rated current of the ACS unit, for the input circuit (InA);
- IP protection rating (should be at least IP44, in which the first digit - the degree of protection against access to hazardous parts and against the penetration of foreign solids, including dust & the second digit - the degree of protection against the penetration by water);
- the weight of the unit, if it exceeds 30 kg.

All construction switchboards should meet the requirements of Polish Standard PN-EN 61439-4:2013-06, the standard of which should be placed on the switchboard ID nameplate.

Each building switchgear should also include information of the ownership of the RB (company name) and contact information to the person responsible for the technical condition of said unit.

Portable pass-through switchgears (MRP) & Portable measurement systems (MUP)

The switchgears are designed to transfer power at the level of 50/75/100/150kW (currents of 75/100/150//200A per phase). MRPs are equipped with an energy measurement system (sEAB meter) together with a remote consumption reading module (proBOX) via the ENERGIA system, and are equipped with the necessary protections on the recipient's side.

MUP - switchgears are adapted for power transfer up to 40kW - equipped with a sNAB meter protected by a 63A fuse and a remote reading device, a connection cable with a 63A plug and a 63A socket for the recipient. Marked as MUP1-100

MRP and MUP switchgears are distributed on individual areas of operations for Electrical Power Distribution Department (WED), the responsibility for the units proper exploitation rests on the individual Shift Masters – Managers by the WED Department.

MRPs have been divided into two sections, closed with doors and padlocks. The left side of the MRP - the connection side, where the MRP power cable is placed and the main protection and the metering and reading system are located. This compartment is the responsibility of the staff of the WED Department Operators (OPP) - after connecting and taking measurements, the compartment is closed by the OPP. On the right side of the MRP is the recipient's compartment - there are connections and outflow protection for the recipient. The Contractor receives one key

	SAFETY STANDARDS	ORLEN S.A.
Version: January 2024	OCCUPATIONAL HEALTH AND SAFETY EXECUTIVE GUIDELINES FOR CONTRACTORS	Page no.: 87

to this part - after acceptance from the OPP and signing of the connection protocol the recipient is fully responsible for the MRP.

In the possession of the WED Department (at the Shift Master - Manager) there are always keys - a set for the left door of the MRP and a reserve key for the right side of the MRP.

MUPs are a single box with one door, the connection space shall be protected against unauthorized access and sealed. MRP and MUP switchgears after being energized are automatically visible in the ENERGIA reading system. Meters have their own internal memory, and reading devices NUMERON, record them once a day during night shift. Therefore, it is very important to have information from the contractors about the end of consumption - to additionally "read" the consumption data before disconnecting the MRP.

Responsibilities of the Shift Master – Manager of WED Department in scope of MRP (MUP):

- Designation on the MRP (MUP) number in the application for connection
- Issuing to WED Department Production Process Operator the admitted MRP (MUP) together with a set of 2 keys and the application for connection, to perform its connecting.
- Claiming of the completed & signed by the Production Process Operator and the recipient, application with 1 key to the left section of the MRP.
- Scanning and resending a copy of the application & the protocol of connection to the services of WED and Power Trade Department of Custom Contracts (EHU).
- Input of data about the connection to the "MRP for recipients – connection history" sheet.
- After the notification by the recipient of completion of power intake, the Shift Master – Manager of WED selects a WED Production Process Operator to execute a disconnection and issues a key to the specific MRP (MUP). After the disconnection of said MRP (MUP) from power, the WED Production Process Operator and the recipient both sign the protocol (pre-completed with data for the disconnection) and the MRP (MUP) is removed by the Shift Master – Manager of WED
- Shift Master – Manager of WED makes a copy of the signed disconnection protocol for WED Department, EHU Department and supplements data in the aforementioned sheet.
- MRP (MUP) switchgear that was disconnected and was returned to the Shift Master – Manager of WED shall be marked (labeled information on the case) to which recipient the unit was assigned for use, so that in case of further need of connection by a specific recipient, the same switchgear can be used (applicable if possible).

Responsibilities of the WED Production Process Operator of WED Department in scope of MRP (MUP):

- Executing the connection of MRP (MUP) unit, issued by the Shift Master – Manager, to the grid of the Production Facility in Płock, in the location specified in the application.
- Performing measurements of electric-shock protection effectiveness insulation of the connection cable.
- Switching on the voltage and checking display of power on the side of the Recipient.
- Completion & signing of the connection protocol of MRP (MUP). Protocol must be signed by both the operator and the recipient.
- Locking the left section door of the MRP and giving the key to the right section door of the MRP to the recipient.
- Handing over the protocol and the key to the Shift Master – Manager of WED.
- During disconnection, retrieving the key from the Shift Master – Manager of WED and the connection protocol of MRP.

	SAFETY STANDARDS	ORLEN S.A.
Version: January 2024	OCCUPATIONAL HEALTH AND SAFETY EXECUTIVE GUIDELINES FOR CONTRACTORS	Page no.: 88

- Visual inspection of MRP (MUP) in the presence of the recipient – making sure there are is no damage to the unit.
- Disconnecting the MRP switchgear (MUP) completing of proper sections & signing of the disconnection protocol. Protocol must be signed by both the operator and the recipient. Retrieving the key to the MRP (MUP) from the recipient.
- Returning the switchgear from the location to the Shift Master – Manager of WED.
- Handing over the protocol of disconnection and the Keys to the MRP (MUP) to the Shift Master – Manager of WED.

Responsibilities of the power recipient in scope or MRP (MUP):

- Conducting the process of completing the application for temporary powering.
- Recipient must have a contract to draw electric power.
- Be present during connection by the WED Production Process Operator of the admitted MRP (MUP), acceptance of the key to the right section door of the switchgear and assuming full responsibility for the MRP (MUP) unit and the attached owner’s inspections.
- Recipient is responsible for any damage to the switchgear during its use.
- Notifying the Shift Master – Manager of WED of the intention to end power intake.
- Be present during disconnection of the MRP (MUP), signing the disconnection protocol and returning the key to the MRP (MUP).

Labelling of the Switchboards:

Each construction switchboard (including MRP, MUP) shall be labelled according to the template, as per attachment no 42. The responsibility of labelling rests on the recipient.

Extension cords

To power a contractor’s power-tools used at the construction site/ renovation site on an Installation, portable industrial extension cords rolled onto a reel (usually a drum) are used. These are fitted with thermal protection or overcurrent protection.

Portable industrial extension cords on a reel are manufactured for rated currents of: 16 A, 32 A, 63 A. The rating of the extension cable is indicated on the rating plate or on a special tag. It must be ensured that the sum of the rated capacities of all power receivers, simultaneously loading the extension cord sockets, does not exceed its rated capacity.

Remember

- The use of extension cords intended for domestic or similar use is prohibited on the construction/renovation site.
- The use of extension cords (or power distributors) without a protective conductor is prohibited at the construction/renovation site.
- The use of single-phase and 3-phase extension cords and other cables used for the distribution of power at the construction/renovation site shall be resistant to mechanical damage and the effects of water.
- Before each use, the extension cord must be visually inspected - check the plug and sockets proper condition and that the insulation is not damaged. If any damage is found to the extension cord, it must be removed from use. Damage must be reported immediately to the direct supervisor. The damaged extension cord must be replaced with a new one.
- It is forbidden to repair the extension cord by wrapping the damaged areas with insulating tape, as this does not provide the required level of electric shock protection and does not

	SAFETY STANDARDS	ORLEN S.A.
Version: January 2024	OCCUPATIONAL HEALTH AND SAFETY EXECUTIVE GUIDELINES FOR CONTRACTORS	Page no.: 89

effectively protect the damaged area against water penetration.

- The maximum length of the extension cord from the construction switchboard must not exceed 50 m.

Power tools

The use of a power tool results from its intended use and the technological needs of the work process. All works with the use of a power tool should be carried out based on the Contractor Safety Method Statement (IBWR). The selection of appropriate personal protective equipment for an employee operating a power tool should be based on the hazards resulting from the device's instruction manual, occupational risk assessment, hazards disclosed in IBWR and measurements of harmful factors at the workplace.

All power tools used on the construction site should meet the requirements set out in the regulations on the conformity assessment system and should be marked with the CE mark.

A damaged power tool should not be started or be immediately stopped, disconnected from the power supply, taken out of service and handed over for repair. A defective tool should be properly secured against accidental use and marked with a warning label.

Power tools marking:

Power tools should be marked with insulating tape in a color corresponding to a given quarter in each subsequent year.

The following colors have been established:

- White – (I quarter – January February March)
- Green – (II quarter – April May June)
- Red – (III quarter – July August September)
- Blue – (IV quarter – October November December)

Below is a graphical example of the correct labeling of devices:

	<p style="text-align: center;">SAFETY STANDARDS</p>	<p style="text-align: right;">ORLEN S.A.</p>
<p>Version: January 2024</p>	<p style="text-align: center;">OCCUPATIONAL HEALTH AND SAFETY EXECUTIVE GUIDELINES FOR CONTRACTORS</p>	<p style="text-align: right;">Page no.: 90</p>

I kwartał



II kwartał



III kwartał



IV kwartał



Each company is obliged to mark power tools in the manner indicated above, and keep a register of power tool inspections, inspection cards for each tool.

Inspect each time before operating a power tool:

- plug - whether it is not cracked, burnt, the pins are not deformed and whether the plug meets the requirements in the part concerning the rated parameters for the tested power tool,
- cord - for damage, protection against pulling out of the plug and power tool (visually or manually), insulation damage (if it is not cut, crushed, burnt, etc.), and whether the cord meets the requirements in the part concerning the type and nominal parameters required for the tested power tool,
- operation of the controls (buttons, knobs, locks, etc.) and whether the elements are not damaged),
- casing completeness, cracks, losses,
- completeness of the covers and the possibility of their certain full adjustment,
- completeness of handles and clamps of working tools and that they do not show any damage.

Also make sure that:

- the accessories, eg the blade, are not damaged and will be used as intended,
- there are no grease leaks indicating seal damage,
- the idling tool runs smoothly, without vibrations and excessive noise,
- the device has a functional switch - do not use the device if it cannot be switched on and

	SAFETY STANDARDS	ORLEN S.A.
Version: January 2024	OCCUPATIONAL HEALTH AND SAFETY EXECUTIVE GUIDELINES FOR CONTRACTORS	Page no.: 91

off with this switch.

Power Generation sets

Power Generating sets (e.g. generators, gen-sets) operated on site are most often used when it is not possible to supply electricity from the distribution network, e.g. during the construction of linear facilities or in the early stages of construction sites.

At such time, they are used as:

- a primary power source to supply an electrical installation not connected to the distribution network (e.g. in conditions where there is no access to the distribution network), or
- a power supply for certain portable appliances or machinery not connected to the electrical system, or
- together with an electrical installation,
- a power source for back-up facilities before the construction site is connected to the distribution network.

The requirements for Power Generation sets vary depending on their purpose, power rating and mode of operation. In practice, portable and mobile diesel-electric generator sets are used to supply an electrical system on a construction site. On larger construction sites, combined generator sets may be used.

The operation of the power generator set must be carried out in accordance with the original instructions (manual), in Polish language, supplied by the manufacturer (distributor), which shall be made available to the employee for permanent use. The manual shall include instructions for installation, operation and maintenance of the power generating set, in particular a description of how to perform grounding of the unit and identification of cases when the unit can be operated without grounding.

When using a power generation set, special attention should be paid to the type of fuel (petroleum, diesel) and the fire hazards that occur during refueling, as well as hazards during exhaust emission.

Fuel must only be poured through suitable funnels to prevent spillage, and only when the unit is completely shut-off and the unit casing is cooled. If the power generator set is operated indoors, discharge of exhaust fumes to the outside of the building must be ensured. When the combustion engine is in operation, the employees should occupy positions so that the exhaust fumes are not ejected directly at the workstation.

During fueling of fuel tanks it is prohibited to use open flame, including the prohibition of smoking and any activity where sparks may occur.

Remember

- All connections, repair, inspections & maintenance of installations, electrical equipment may only be performed out by personnel with an electrician's qualification certificate (group I, D+E qualification).
- All electrical equipment in use shall have a minimum protection level of IP44.
- Electrical cables supplying power to the equipment, including extension cords, should be H07 RN-F type or equivalent, resistant to abrasion and water.
- All cables supplying power to the equipment, including extension cords, shall have full and undamaged primary and secondary insulation.
- Residual current devices shall be used in power supply circuits.

 ORLEN	SAFETY STANDARDS	ORLEN S.A.
Version: January 2024	OCCUPATIONAL HEALTH AND SAFETY EXECUTIVE GUIDELINES FOR CONTRACTORS	Page no.: 92

- Construction switchboards are to be locked and protected from unauthorized access at all time.
- A documented inspection (in appendix 42) of the residual current device by a service electrician (external visual inspection and TEST function check) must be carried out every day before switching on the Construction switchboard.
- Electrical cables must be laid & managed in such a way to eliminate risk of people on site to trip over on them, grip or entrap limbs.
- Wires located in pedestrian routes, e.g. on staircase flights, must be laid & managed by the walls and secured to prevent uncontrolled movement.
- Electrical cables lying in traffic routes must be protected against mechanical damage, e.g. they should preferably be suspended or covered.
- Powered electrical sockets should have a sealed and undamaged casing to prevent access to live wires.

Not Allowed

- It is prohibited to power workstations on a construction/renovation site from installations with protection by melting fuses.
- It is prohibited to open switchgears and touch internal electrical system in the switchgears by personnel without proper electrician's qualification certificate.
- It is prohibited to use damaged cables repaired with insulating tape.
- It is prohibited to use torn-out sockets or plugs with damaged casing.

34. Guidelines for the management of assembly auxiliary lifting equipment.

Each Contractor should comply with the following guidelines regarding the fulfillment of safety conditions in the field of managing assembly auxiliary lifting equipment while carrying out works on the premises of ORLEN S.A.

1. Assembly auxiliary lifting equipment – component or equipment not related to the lifting machine, including slings and their components, enabling the load to be held, placed between the machine and the load or on the load itself or which may form an integral part of the load, which are placed on the market separately, hereinafter referred to as **assembly auxiliary lifting equipment**.

The assembly auxiliary lifting equipment can include:

Due to the construction:

- **Multi-leg slings** (two-, three- and more), which must be connected by a ring or shackle and the load must be properly distributed so that no cable is overloaded.

Angle between cables [°]	Obtained performance relative to safe working load
0	100
60	80
90	70
120	50

	SAFETY STANDARDS	ORLEN S.A.
Version: January 2024	OCCUPATIONAL HEALTH AND SAFETY EXECUTIVE GUIDELINES FOR CONTRACTORS	Page no.: 93

When using this type of device, the angle between the sling legs, chains or ropes must not exceed 120° .

Due to the material, from which they are made:

- **Chain slings** that may only be modified or repaired by a specialist company and must be inspected or checked before being used again. Chain slings may only be shortened using appropriate shortening couplings. It is forbidden to tie chains or connect them with bolts and nuts, they must not wrap around pipes, beams or bundles. These types of slings must be clearly marked with their maximum load capacity and chain class.
- **Wire rope slings** can be damaged when sharply "bent" or when under tension when coiled. Steel wire rope can be damaged by corrosion if not properly maintained and stored.
- **Webbing (textile) slings**, which are more susceptible to cuts and damage and should be visually inspected by the user before each use to ensure serviceability. Although they do not rot, care should be taken as they may be susceptible to certain chemicals.
- **Slings made of textile or synthetic ropes** - only certified, technically efficient slings with the manufacturer's instructions are allowed for use.

When selecting the appropriate sling for the transported material, special attention should be paid to whether a different method of transport is provided for a given load and the following should be taken into account:

- Sling usage intensity,
- Type of the load,
- Anchor points,
- Weight and size of the load,
- The load's center of gravity,
- External conditions such as: temperature, wind strength,
- Sharp edges.

2. Follow the manufacturer's strict instructions contained in the technical and operating documentation (DTR) or the equipment manual.

3. If there is no information in the DTR documentation about the use of the equipment in various conditions, the following criteria should be used, and in the case of different sources of information about conditions, more stringent conditions should be applied.

4. In the absence of information for a particular type of condition, please contact the manufacturer.

5. All ropes, chains, slings, shackles, eyebolts, chain blocks must be clearly marked with their **permissible working load** (DOR). Individual and unique identification codes to trace records of their previous inspections and tests must be available on the work site or company premises.

6. Ropes, chains and slings must be properly attached to lifting devices in an approved manner, either by attaching the gear directly to the hook, if the size of the attachment allows it, or by

	SAFETY STANDARDS	ORLEN S.A.
Version: January 2024	OCCUPATIONAL HEALTH AND SAFETY EXECUTIVE GUIDELINES FOR CONTRACTORS	Page no.: 94

using a suitable shackle. The shackle part with the attachment pin is placed on the hook and the lifting gear must be on the bend of the shackle.

7. The correct slinging method varies depending on the type of load, materials or objects being lifted.
8. Ropes, chains and slings must not be overloaded except when tested and approved by an experienced and competent person.
9. Edges and corners of chains must be protected with edge protectors to prevent sharp edges from damaging ropes, chains or lifting slings.
10. The edge protector radius must not be smaller than the thickness of the sling or the diameter of the rope. Only factory-produced edge protectors may be used. The use of worn, discarded or dismantled textile slings and similar materials is not allowed.
11. It is necessary to use guiding ropes securely attached to the end point of the load (directional ropes) in order to direct the load to the required position and prevent it from twisting. Guiding ropes should be as short as is reasonable and practical, however, they should always provide the user with "safety through distance".
12. Knots or loops should not be allowed to form - the sling must not be shortened or joined, allowing knots to be braided or used.
13. If the lifting procedure requires the use of several slings, all slings must be identical in material, capacity and length.
14. The slings must not be used for pulling, causing exposure to excessive friction (abrasion, scraping), they must not be dragged along the ground or rough surface.
15. Before lowering the load down - if it is necessary to separate the slings - the base should be placed. The sling cannot be separated if the load rests on it. Excessive, long-term load on the slings may damage them.

THOROUGH TESTING OF THE ASSEMBLY AUXILIARY LIFTING EQUIPMENT.

1. All load-lifting equipment must be subject to thorough examination by a competent person, within the time limits specified in the manufacturer's instructions or technical documentation of the equipment.
2. A thorough inspection must also be carried out after any event which may affect the safety of any lifting or load handling equipment. All temporary devices must undergo a thorough examination after installation and before the first use. All valid test certificates must be available at the construction site, work site or company premises.
3. All tests must be recorded in the appropriate log (device operation sheet). The records must be reliable and match the device identifiers.
4. The slings should be immediately withdrawn from use for repairs if the following defects have occurred:

	SAFETY STANDARDS	ORLEN S.A.
Version: January 2024	OCCUPATIONAL HEALTH AND SAFETY EXECUTIVE GUIDELINES FOR CONTRACTORS	Page no.: 95

- Lack or illegible marking (identification numbers, DOR).
- Heat damage.
- Deformation, cracks in links, hooks.
- Bent or twisted links or hooks.
- Excessive chain elongation.
- A cluster of broken wires.
- Severe permanent deformation of the rope.
- Rope wear - diameter over 10% of the nominal value.
- Strong corrosion.
- Noticeable loss of rope elasticity.
- Locking of mechanical fasteners.
- Defective latch protection.
- A tear or cut in the fabric in excess of 10% of the width of the sling.
- Abrasion of the wire protecting the belt on the links and shackles.
- Suture damage.
- Opening the hook latch by at least 10%.

REGISTER OF THE ASSEMBLY AUXILIARY LIFTING EQUIPMENT.

1. In accordance with the minimum formal requirement, all elements of lifting equipment must be entered in the register of assembly auxiliary lifting equipment constituting **Annex No. 43** to the above-mentioned guidelines, hereinafter referred to as the Register. The Register should contain basic equipment data, such as e.g. name of the equipment, permissible working load (DOR), identification number, lifting capacity, length, place of storage of the equipment, date of the equipment's detailed inspection, date of the next detailed inspection, etc.

The Register should be available during the works on the premises of ORLEN SA from the operator of the Handling Equipment (UTB) - if the equipment is part of such a device or from the Contractor's Works Manager responsible for the works carried out on the premises of ORLEN SA.

The Register must be updated on an ongoing basis and archived until the end of the project: renovation, investment or as part of ongoing maintenance, and available at any time for verification by preventive services on the part of the Employer and other services.

STORAGE AND MAINTENANCE AND NON-CONFORMING EQUIPMENT.

1. The slings should be stored in designated places on racks or boxes to avoid their damage as a result of moisture, fire, high temperature, chemical factors or undesirable loads.

2. Contaminated elements of webbing slings that have been in contact with acids or alkalis should be rinsed thoroughly in cold water.

3. Only use neutral cleaning agents for cleaning.

4. Drying must occur naturally. External drying is not allowed.

5. Any non-conforming lifting devices and equipment, e.g. without identification numbers, without permissible working load limit (DOR) markings, broken, damaged or malfunctioning, not examined or inspected within the required time limits, etc. must be immediately withdrawn from use and destroyed, removed from the construction site, renovated facility or locked in a separate place until the non-compliance is removed.

	<p style="text-align: center;">SAFETY STANDARDS</p>	<p style="text-align: center;">ORLEN S.A.</p>
<p>Version: January 2024</p>	<p style="text-align: center;">OCCUPATIONAL HEALTH AND SAFETY EXECUTIVE GUIDELINES FOR CONTRACTORS</p>	<p style="text-align: center;">Page no.: 96</p>

35. Additional guidelines regarding the use of detectors

1. Until the end of Q4 2024 all Contractors' employees working on active (working) production installations and fuel terminals must be equipped with individual detectors, which should provide protection against chemical hazards. Employees must have personal multi-gas detectors attached and turned on, the type depending on the given location:
 - for ORLEN S.A. Production Plants (Płock/Gdańsk/Włocławek): multi-gas personal detector with minimum sensors: **LEL** (lower explosive limit), toxic gas **H2S**. Recommended: **LEL, H2S, O2**
 - for Fuel Terminals outside Płock, a personal detector with a minimum of LEL sensors (lower explosive limit).
2. In the case of work carried out during the renovation of an installation from which hazardous substances have been removed, the mandatory obligation to use detectors may be waived. Additionally, in the case of newly built production installations, until hazardous substances are introduced into the installation, the obligation to use personal detection does not apply.
3. ORLEN S.A. will inform about the need to use personal detectors at the bidding stage.
4. Before starting works on the production facilities, ORLEN S.A. will communicate the planned date of removal of hazardous substances, and thus lack of necessity to use personal detectors.
5. In the case of work carried out during the renovation of an installation from which all hazardous substances **have not been removed**, the obligation to use individual detectors may be waived if ORLEN S.A. uses zone detectors calibrated for hazards from gases remaining in the installation.
6. If the person issuing the work permit indicates the need for the Contractor to use individual detector, despite the earlier abolition of the obligation to use it, ORLEN S.A. will be responsible for equipping the Contractor with individual detection. (equipment from own funds, rental to the Contractor or rental costs) or an additional scope will be issued for the Contractor related to rental costs.
7. If necessary, the Contractor may use the detector rental located at the Production Facility in Płock, run by a company from the ORLEN Capital Group.
8. Regardless of the type of works performed on active and renovated installations and fuel terminals, in all work in confined spaces, employees must be equipped with individual detectors with additional measurement of oxygen concentration in the air. Employees must have their detectors attached and turned on.
9. The obligation to use personal detection by Contractors will be introduced from January 1, 2025.
10. Minimum requirements for individual detection for Contractors:
 - a. EU declaration of conformity and CE certificate,
 - b. Explosion-proof (zone "0"),
 - c. Acoustic and optical warnings,
 - d. Sensitivity/resolution of sensors enabling setting alarm thresholds in accordance with table no. 1),
 - e. Possession of a valid calibration certificate (calibration of devices in accordance with the manufacturer's recommendations, but at least once every 6 months).

 ORLEN	SAFETY STANDARDS	ORLEN S.A.
Version: January 2024	OCCUPATIONAL HEALTH AND SAFETY EXECUTIVE GUIDELINES FOR CONTRACTORS	Page no.: 97

Alarm threshold	SENSOR TYPE												
	DGW	O2	H2S	H2	NH3	SO2	Cl2	CO	CO2	HF	ETO (ethylene oxide)	VC (polyvinyl chloride)	PID
Low	8% LEL	20%	4 ppm	200 ppm	14 ppm	0,3-0,4 ppm*	0,1-0,2 ppm*	18 ppm	0,3% obj = 3000 ppm	0,3 ppm		0,5 ppm	4
High	10% LEL	22,5%	5 ppm	400 ppm	20 ppm	0,5 ppm	0,2 ppm	20 ppm	0,5% obj = 5000ppm	0,6 ppm	0,1 ppm	1 ppm	5

• - the service will set a given parameter depending on the sensitivity of the sensor in the detector

Table no. 1

11. The obligation to use personal detectors does not apply to drivers of road tankers delivering and receiving chemical substances from ORLEN S.A. and external Contractors at fuel terminals outside Płock carrying out works outside the terminal's technological installation.



ORLEN S.A.

.....
(stamp of an issuing unit)

**LONG-TERM PERMIT No.
for renovation works**

I. Validity period of the permit

II. Work contractors

1)

2)

3)

III. Name of structure, junction, set of apparatuses, equipment

.....
.....

IV. Allowed, by the permit, scope of renovation works

.....
.....

V. I have been familiarised with the settlements given in attachments and undertake to comply with them absolutely:

1) (date) (surname and first name of Contractor) (signature)

2) (date) (surname and first name of Contractor) (signature)

3) (date) (surname and first name of Contractor) (signature)

VI. I acknowledge completion of the settlements included in attachments determining safe conditions of performing works and I request admission of their commencement:

.....
(date)

.....
(stamp and signature of an issuer)

VII. Approved by:

.....
(date)

.....
(stamp and signature of the Approving person)

VIII. Attachments:

- 1)
- 2)
- 3)
- 4)

IX. Distribution:

Contractors:

- 1)
- 2)
- 3)
- 4)

Issuer:

Approving person:

CAUTION!

Based on the present permit it is absolutely forbidden to perform particularly hazardous works.





ORLEN S.A.

.....
(stamp of an issuing unit)

REQUEST

for issuing a long-term permit for conduct of investment works for the structure

.....
within the time-limit from to

1. Location *(precise determination of territory of investment works taking account of a distance from structures and equipment under use)*

.....
.....
.....
.....

2. Proposed conditions and recommendations

.....
.....
.....

.....
(date)

.....
(stamp and signature of a Requesting person)

3. OPINIONS AND RECOMMENDATIONS

1) Manager

.....
.....

.....
(date, stamp and signature)

2) Manager

.....
.....

.....
(date, stamp and signature)

3) Manager

.....

.....
(date, stamp and signature)

4) Person managing the Water & Wastewater Plant

.....
.....
.....

.....
(date, stamp and signature)

5) Person managing the Central Department for Scheduling and Coordination of Production

.....
.....

.....
(date, stamp and signature)

6) Person managing the Group OHS and Prevention Coordination Department

.....
.....

.....
(date, stamp and signature)

7) Head of the Company Fire Brigade

.....
.....

.....
(date, stamp and signature)



ORLEN S.A.



Annex No. 3

.....
(stamp of an issuing unit)

**LONG-TERM PERMIT No.
for investment works**

I. Validity period of the permit

II. Location

III. Kind and scope of works

IV. Contractors

V. Safety conditions

VI. Permit does not refer to

VII. Responsibility for fulfilment of conditions mentioned in point V and supervision during works shall lie with the issuer of the permit

.....
(date, stamp and signature of the issuer)

APPROVED BY:

.....



ORLEN S.A.

.....
(stamp of an issuing unit)

REQUEST

for issuing a long-term permit for conducting works with the use of open fire for the structure
within the time-limit from to

1. Location *(precise determination of structure (workshop) taking account of a distance from structures and equipment under use).*
.....
.....
.....

2. Proposed conditions and recommendations *(protection by means of handheld firefighting equipment)*
.....
.....
.....
.....
(date) (stamp and signature of a Requesting person)

3. OPINIONS AND RECOMMENDATIONS

1) Owner or Leaseholder (of a structure, territory).....
.....
.....
(stamp and signature)

2) Neighbouring technological structures
.....
.....
(stamp and signature)

3) Group OHS and Prevention Coordination Department
.....
.....
(stamp and signature)

4) Company Fire Brigade
.....
.....
.....
(stamp and signature)



Annex No. 5

ONE - OFF PERMIT No.

[Empty box for permit number]

for performance of particularly hazardous works

for

[Empty box for contractor name]

(Contractor)

(stamp (name) of an issuing cell)

- I. Work with use of open fire
- Work inside a container, apparatus*
- Opening of apparatuses, pipelines and equipment after emptying
- Work with power devices
- Work inside drains*
- Work at height
- Earthworks
- Work with the use of dangerous materials

II. Valid on from (time) to (time)
 prolonged to (time)

(stamp and signature)

III. Place of work (specify precisely)

installation, plot
 junction
 apparatus no.
 level
 overpass
 mogul
 other

IV. Scope and kind of work (specify precisely)

scope of work

 equipment used

It is allowed to carry out works inside an apparatus without
 equipment for protection of respiratory tract: YES NO
 Contractor shall be obliged to tidy up the territory after completion of works.

V. Number of persons in the team performing work: staff members
 (not more than 25 staff members)

VI. Existing and anticipated risks: (specify precisely)

kind (character) of threats

way of conduct in the event of a threat

.....

 place of evacuation

VII. Preparation of workplace: *(specify precisely)*

OPERATION OF INSTALLATION	YES / NO			YES / NO	
• emptying	<input type="checkbox"/>	<input type="checkbox"/>	• turning on voltage	<input type="checkbox"/>	<input type="checkbox"/>
• blowing through with nitrogen	<input type="checkbox"/>	<input type="checkbox"/>	• closure of road / railway track	<input type="checkbox"/>	<input type="checkbox"/>
• cut off with a closing component	<input type="checkbox"/>	<input type="checkbox"/>	CONTRACTOR		
• plugging	<input type="checkbox"/>	<input type="checkbox"/>	• preparation of scaffoldings	<input type="checkbox"/>	<input type="checkbox"/>
• disinfection, neutralisation	<input type="checkbox"/>	<input type="checkbox"/>	• carry out lightning	<input type="checkbox"/>	<input type="checkbox"/>
• cleaning	<input type="checkbox"/>	<input type="checkbox"/>	• insulation		
• air blowing	<input type="checkbox"/>	<input type="checkbox"/>	disassembly	<input type="checkbox"/>	<input type="checkbox"/>
• turning off voltage	<input type="checkbox"/>	<input type="checkbox"/>	• fencing of a dangerous zone	<input type="checkbox"/>	<input type="checkbox"/>
			• protection of flammable materials	<input type="checkbox"/>	<input type="checkbox"/>
• first aid point					
• other					

VIII. Protection of an adjacent territory: *(specify precisely)*

CONTRACTOR	YES / NO	
• protection against sprinkling of sparks	<input type="checkbox"/>	<input type="checkbox"/>
• fencing of the territory	<input type="checkbox"/>	<input type="checkbox"/>
• warning boards	<input type="checkbox"/>	<input type="checkbox"/>
• making of shields, curtains	<input type="checkbox"/>	<input type="checkbox"/>
• protection of excavation walls	<input type="checkbox"/>	<input type="checkbox"/>
• protection of manholes, drains within a radius of 20m	<input type="checkbox"/>	<input type="checkbox"/>
• sprinkling with water	<input type="checkbox"/>	<input type="checkbox"/>
• suspension of road and railway traffic	<input type="checkbox"/>	<input type="checkbox"/>
• indication of a contractor of dangerous zone	<input type="checkbox"/>	<input type="checkbox"/>
• other		

IX. Protective measures

1. Safeguarding / safety posts,
permanent installation fire brigade contractor
periodic installation fire brigade frequency, every hours
 other

2. Protective equipment and clothes - *as a standard: anti-static clothes and footwear, anti-splinter helmet and glasses, protective gloves*

- protective clothes of the following type
- dust masks
- gas masks

- tight chemical goggles
- face shields
- hearing protectors
- safety harness
- self-inhibitory device
- safety shock-absorber
- safeguarding rope
- fresh air apparatuses
- sound signalling device
- breathing apparatuses
- signal line
- alarm device for employee immobility
- other

3. Fire fighting handheld equipment *(Contractor shall be responsible for application of relevant equipment).*

Portable equipment (fire-extinguisher):

- carbon-dioxide extinguisher min. 5kg pcs
- dry-powder extinguisher min. 5kg pcs

Mobile equipment (unit):

- carbon-dioxide
- dry-powder

Additionally:

- fire blanket
- sprinkling

other

4. Analytical control:

- required not required
- explosiveness oxygen content toxicity temperature

max. 30 min before commencement of works and every hours during performance of work.

other
.....

5. Other:

- | | YES / NO | |
|--|--------------------------|--------------------------|
| • Company Fire Brigade notification | <input type="checkbox"/> | <input type="checkbox"/> |
| • Central Production Scheduling and Coordination Department notification | <input type="checkbox"/> | <input type="checkbox"/> |
| • notification of adjacent organisational units | <input type="checkbox"/> | <input type="checkbox"/> |
| • notification of other services depending on the situation and needs | <input type="checkbox"/> | <input type="checkbox"/> |
| • instructions for the Contractor | <input type="checkbox"/> | <input type="checkbox"/> |
| • other | | |

X. Settlements

It has been settled with
.....
within the scope of
.....

XI. Persons connected with use of the permit:

Project Implementation Manager (applies to investment processes)

.....
(date, signature, stamp)

1. I have been familiarised with and I comply with provisions of points I-IX:

Workplace preparation.	
..... first name and surname legible signature

Operational Safeguard or Person verifying (accepting) permits in investment processes.	
..... first name and surname legible signature

Contractor's Safeguarding - person managing staff members.	
..... first name and surname legible signature

2. Analytical control. I have received, for implementation, the establishments of point IX.4

..... first name and surname legible signature

3. Power, mechanical, measurement and automatics protection (confirmation by a Head, master or operator of the power industry as well as measurement and automatics with relevant power entitlements).

The scope of works specified in point VII has been completed.

..... supervisor's stamp and signature supervisor's stamp and signature supervisor's stamp and signature

4. Settlements (point X - confirmation by minimum a Master).

..... stamp and signature stamp and signature stamp and signature

5. Contractor (person managing staff members). I have been familiarised with provisions of points I-X and I comply with them.

..... first name and surname legible signature

6. Supervisor (person managing staff members or Person verifying (accepting) permits in investment processes). I confirm completion of the settlements of points VI-X.

..... first name and surname - position stamp and signature

XII. I CONFIRM (person who has completed a training in Occupational Health and Safety for management staff or Project Implementation Manager (applies to investment processes).

..... date stamp and signature

XIII. Control after completion of works - exercised by Supervisor or Safeguarding person or Person verifying (accepting) permits in investment processes in presence of Contractor.

Place of performing works has been controlled. The control showed:

.....

Another control / recommendations:

.....

XIV. Statement on completion of works. Works were finished at: (time).

.....

legible signature of Supervisor or Safeguarding person Contractor's legible signature

XV. Attachments

1. Results of analyses:

Measurement equipment number.....

2. Other

Explanation:

* - checking the item: "***work inside a container, apparatus***" or "***work inside drains***" shall result in issuing the "***Card of entry into a container***" and placing it in a visible place outside the container.

** - delete as appropriate

CAUTION!

This one-off permit is a document which determines safety conditions during performance of works specified in point IV.



ONE - OFF PERMIT No.

for other works

for

(Contractor and contract number)

(stamp (name) of an issuing cell)

I. Valid on from (time) to (time)

prolonged to (time)

(stamp and signature)

II. Place of work *(specify precisely)*

- installation, plot
- junction
- apparatus no.
- level
- overpass
- mogul
- other

III. Scope and kind of work *(specify precisely)*

- scope of work
- equipment used

The Contractor is obliged to tidy up the territory after completion of works.

IV. Number of persons in the team performing work - ...staff members *(not more than 25 staff members)*

V. Existing and anticipated risks: *(specify precisely)*

kind (character) of threats

way of conduct in the event of a threat

place of evacuation

VI. Preparation of workplace: *(specify precisely)*

OPERATORS ON INSTALLATION	YES / NO	YES / NO
• emptying	<input type="checkbox"/> <input type="checkbox"/>	• turning on voltage <input type="checkbox"/> <input type="checkbox"/>
• cleaning	<input type="checkbox"/> <input type="checkbox"/>	• closure of road / <input type="checkbox"/> <input type="checkbox"/>
• cut off with closing components	<input type="checkbox"/> <input type="checkbox"/>	railway track

- plugging CONTRACTOR
- turning off voltage
 - carry out lightning
 - insulation
 - disassembly
- other

VII. Protection of an adjacent territory: *(specify precisely)*
OPERATOR ON INSTALLATION YES / NO
 • suspension of road and railway traffic
 • other

CONTRACTOR YES / NO
 • warning boards
 • fencing of the territory

VIII. Protective measures

1. Safeguarding

- permanent** movement contractor
periodic movement - frequency, every hours
 other

2. Protective equipment and clothes - *as a standard: anti-static clothes and footwear, anti-splinter helmet and glasses, protective gloves*

- protective clothes of the following type
- dust masks
- protective goggles
- face shields
- hearing protectors
- gas masks
- other

3. Instructions for Contractor YES NO

IX. Settlements

It has been settled with
 within the scope of

X. Persons connected with use of the permit:

1. I have been familiarised with and I comply with provisions of points I-IX.

Person preparing the workplace	
.....
name/surname	legible signature

Operational **Safeguard:**

Contractor's **Safeguard**

.....
 first name and surname legible signature first name and surname legible signature

2. Power, mechanical, measurement and automatics protection *(confirmation by a Head, master or operator of the power industry as well as measurement and automatics with relevant power entitlements).*

Annex no. 7

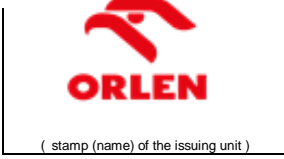

ONE-OFF PERMIT NO.

for vehicle entry

I. Valid on day(s) **from (time)** **to (time)**

II. Vehicle work area, access route

.....

III. The scope and type of work

.....

<p>IV. Vehicle type</p> <p><input type="checkbox"/> internal combustion</p> <p><input type="checkbox"/> electric</p> <p><input type="checkbox"/> lifting</p>	<p>V. Auxiliaries</p> <p><input type="checkbox"/> cable sling</p> <p><input type="checkbox"/> catch and hook sling</p> <p><input type="checkbox"/> special sling</p>
---	---

VI. Vehicle registration number (other)

VII. Restrictions and precautions

Secure drains and grates within a 20 m radius of the vehicle's working area (the installation's operator is responsible). Fence the vehicle work area, equip the vehicle with a fire extinguisher (responsible - the permit taker). In the event of a hazard, the permit taker immediately shuts off the vehicle's engine, leaves the vehicle and notifies the permit issuer

In addition, it is prohibited :

- leaving the engine running without service or leaving the key in the ignition ,
- using non-approved slings ,
- exceeding the sling's DOR.

other

VIII. Analytical control required not required – renovation mode

Analysis performed by: _____
Name and Surname (legible signature)

Type, analysis results and number of measuring equipment:

Permit issued by: _____
Name and Surname (stamp and signature)

Permit accepted by: _____
Name and Surname (legible signature of the driver - operator)

The driver or operator of the vehicle at work must have a work permit at the workplace

QUESTIONNAIRE
preparing the Contractor for particularly hazardous works
(completed by the Contractor)
RESPONSIBILITY = SAFETY
DANGER = INTERRUPTION OF WORK

Contractor's first and last name

Permit no.

Date

What threats?

	YES	NO	ABSENT
Has the contractor been instructed about the expected and existing hazards during the work included in the permit?	<input type="checkbox"/>	<input type="checkbox"/>	<input type="checkbox"/>
Have the employees been trained by the contractor instructed about the expected and existing hazards during the work included in the permit?	<input type="checkbox"/>	<input type="checkbox"/>	<input type="checkbox"/>
Do the works carried out not pose a threat to other people and the contractors themselves?	<input type="checkbox"/>	<input type="checkbox"/>	<input type="checkbox"/>
Does the contractor have adequate and efficient personal protective equipment?	<input type="checkbox"/>	<input type="checkbox"/>	<input type="checkbox"/>
Does the contractor have adequate and efficient safety equipment?	<input type="checkbox"/>	<input type="checkbox"/>	<input type="checkbox"/>
Does the contractor have technically sound tools and devices?	<input type="checkbox"/>	<input type="checkbox"/>	<input type="checkbox"/>
Are the scaffoldings properly positioned and have an important overview?	<input type="checkbox"/>	<input type="checkbox"/>	<input type="checkbox"/>
Is the work area separated and marked with appropriate warning boards?	<input type="checkbox"/>	<input type="checkbox"/>	<input type="checkbox"/>
Has the work place been protected against sparks?	<input type="checkbox"/>	<input type="checkbox"/>	<input type="checkbox"/>
Did you spray the area with water?	<input type="checkbox"/>	<input type="checkbox"/>	<input type="checkbox"/>
Have curtains or covers been made?	<input type="checkbox"/>	<input type="checkbox"/>	<input type="checkbox"/>
Have sewage sumps and drains been secured within a radius of 20 m from an open flame work site?	<input type="checkbox"/>	<input type="checkbox"/>	<input type="checkbox"/>

Do the contractor's employees know?

	YES	NO
How to proceed in the event of a chemical alarm announcement?	<input type="checkbox"/>	<input type="checkbox"/>
What to do in the event of a fire?	<input type="checkbox"/>	<input type="checkbox"/>
What to do in the event of an accident?	<input type="checkbox"/>	<input type="checkbox"/>
Where are the muster points for evacuation?	<input type="checkbox"/>	<input type="checkbox"/>
Where are the weather vanes - in what direction does the wind blow?	<input type="checkbox"/>	<input type="checkbox"/>

All employees of the Contractor were trained in the performance of particularly dangerous work on the premises of ORLEN and participated in the analysis of threats and know its content

.....
name and surname of the Contractor

.....
legible signature

IT IS PROHIBITED TO ISSUE A WORK PERMIT OR MUST IMMEDIATELY STOP THE WORK IN PROGRESS IF ONE OF THE ANSWERS IN THE RISK ANALYSIS IS "NO !!!!!"

**Annex no. 9**to permit no. **Control activities for the implementation of works.****Analytical control:**

Table No. 1. Analytical control with the frequency specified in point IX.4. of a one-off permit for particularly hazardous work.

Item	Place and time	No. of measuring equipment	The name of the factor and the result of the measurement	A legible signature of the executor
1.				
2.				
3.				
4.				
5.				
6.				
7.				
8.				
9.				
10.				
11.				
12.				
13.				
14.				
15.				



No.

by permit numbers

Name or stamp of an organisational cell

Instructions for safe work implementation

for **agreement no.**.....

concerning performance of works:

- with the use of open fire,
- inside closed containers and apparatuses,
- opening of apparatuses, pipelines and equipment after emptying,
- in drains,
- at height,
- earthworks,
- with the use of dangerous materials,
- performed near unsheltered power devices or their parts alive,
- performed near power unplugged devices, but earthed in such a way that any of the earthings is not noticeable from the place of performing work,
- maintenance, renovation or assembly/installation at unloading devices and installations of liquid and gas fuels,
- renovation and investment,
- other works not included in binding instructions,

on (date): (planned),

from (time): to (time): (planned).

In each day of work a "Daily Card" needs to be issued. - Attachment No. 1 to the present "Instructions" and kept with the "Instructions" for 1 year.

Time of starting and/or ending work needs to be noted each time in the Attachment No. 1 to the Instructions.

A. Number of people in the team performing work (number of staff members): staff members.

B. Place of work (precisely - installation, junction, apparatus no., overpass level, mogul, etc.)

C. Scope and kind of work (scope of work, equipment used).

D. Existing and anticipated threats (kind and character of threats, way of conduct in the event of a threat, place of evacuation, occupational risk assessment).

- E. Preparation of workplace** (emptying; disconnection, unplugging; cleaning; disinfecting, neutralisation; blow through with nitrogen; air blow; voltage turn off; voltage turn on; preparation of scaffoldings; closure of a road, railway track; determination of dangerous zone; lightning; protection of flammable materials; first aid point, etc).

- F. Protection of adjacent territory** (enclosure of territory; warning boards; protection of manholes, drains; protection against sprinkling of sparks; making of shields, curtains; sprinkling with water; protection of pit's walls, discontinuation of road and railway traffic).

G. Protective measures

- safety posts, safeguarding,

- protective equipment and clothes - *as a standard: antistatic clothes and footwear, anti-splinter helmet and glasses, protective gloves,*

- fire protection - handy extinguishing equipment,

- analytical control,

- control of workplace after completion of works,

- other

- notification of the fire brigade,

- notification of the Central Department for Scheduling and Coordination of Production,

- notification of adjacent organisational cells,

- notification of other services, depending on needs,

- instructions for Contractor.

H. Settlements

I. Persons connected with performance of works.

safeguarding from the Production or the person verifying (accepting) permission in investment processes,

safeguarding from the side of contractor,

analytical control,

power, mechanical, measurement and automatics,

settlements.

Contractor,

Supervision or the person verifying (accepting) permission in investment processes

J. Control after completion of works.

K. Statement on completion of work.

L. Annex:

Annex no. 11 – Daily Card

Annex no. 12 - CONFIRMATION OF CONDUCTED INSTRUCTIONS

Drawn up by:

.....

APPROVED BY*:

.....

** Date, signature and stamp of a person entitled to approve one-off permits for particularly dangerous works.*



DAILY CARD*

of (date) , working hours: number of staff members:

1. I have been familiarised with and I comply with the present instructions.

Safeguarding from the side of movement:
First name and surname legible signature

Safeguarding from the side of contractor:
First name and surname legible signature

2. Analytical control. I have been familiarised with and I comply with the present instructions **(Person verifying (accepting) permission in investment processes.)**

.....
First name and surname legible signature

3. Results of analyses - measurement equipment no.:

4. Power, mechanical, measurement and automatics protection. The scope of works specified in the instructions has been made.

.....
legible signature legible signature legible signature

5. Settlements. The scope of works specified in the instructions has been made.

.....
signature and stamp signature and stamp signature and stamp

6. Contractor (person managing staff members). I have been familiarised with and I comply with the present instructions.

.....
First name and surname Legible signature

7. Supervision (person managing staff members or the person verifying (accepting) permission in investment processes). I confirm implementation of the instructions.

.....
First name and surname Signature and stamp

8. Control after completion of works (carried out by Supervisor or Safeguarding person or the person verifying (accepting) permission in investment processes in presence of Contractor)

Place of performance of works was controlled. **The control showed:**

.....
 Another control/ Recommendations:

9. Statement on completion of works. Works were finished at (time):

.....
supervisor's legible signature Contractor's legible signature

10. Twenty-four-hour control. (person approving instructions or the person verifying (accepting) permission in investment processes).

Time of control: Result of control:

.....
First name and surname signature

11. Remarks.

* - issue in each day of work and keep in archives with instructions for 3 years.

**Annex no. 12****CONFIRMATION OF CONDUCTED INSTRUCTIONS***

No.	First name and surname	Date	Signature
1.			
2.			
3.			
4.			
5.			
6.			
7.			
8.			
9.			
10.			
11.			
12.			
13.			
14.			
15.			
16.			
17.			
18.			
19.			
20.			
21.			
22.			
23.			
24.			
25.			

* - issue in the first day of work and with a change in composition of the executive team and keep in archives together with instructions for 3 years.



NAME LIST OF STAFF MEMBERS OF THE EXECUTIVE TEAM

for permit No.

Contract no./Order no. from INFOR (D7i)

No.	First name and surname	Access card No.	Authorised to receive permits (YES)	Required qualifications (YES) ¹⁾
1.				
2.				
3.				
4.				
5.				
6.				
7.				
8.				
9.				
10.				
11.				
12.				
13.				
14.				
15.				
16.				
17.				
18.				
19.				
20.				
21.				
22.				
23.				
24.				
25.				

1) Required qualifications for servicing groups of energy devices in accordance with Annex 1 to the Ordinance of the Ministry of Economy, Labor and Social Policy on the detailed rules for confirming qualifications by persons involved in the operation of devices, installations and networks - in situations when qualifications are required

I undertake to execute the subject of the contract with my own resources.

.....
Date

.....
Contractor's legible signature

Annex no. 16

Job Safety Analysis (JSA) - example

Risk assessment for investment task no./ work related to the contract no	Company, contract no.....	Task (in accordance with the scope of work covered by the contract):	Installation:	Date: <i>dd-mm-yyyy</i>
--	---	---	------------------------	-------------------------

Exposed persons:

Employees:	Subcontractor's employees:.....	Bystanders / guests:	Juvenile (number).....	Total number of people exposed::	Person familiarized with the risk assessment: Work supervisor:
---------------------	---------------------------------	----------------------------	------------------------	---	---

Table of risks

SEVERITY	5	M	M	H	VH	VH
	4	S	M	H	H	VH
	3	S	M	M	H	H
	2	VS	S	M	M	M
	1	VS	VS	S	S	M
		1	2	3	4	5

PROBABILITY

Probability
 1 = Almost impossible
 2 = Unlikely
 3 = Medium
 4 = Probable
 5 = Almost certain

Severity
 1 = Slight injuries
 2 = Light injuries
 3 = Serious injuries
 4 = Heavy injuries
 5 = Fatal injuries

<div style="background-color: #00ff00; width: 100%; height: 15px; margin-bottom: 5px;"></div> <p>Small and Very Small (acceptable)</p>	<div style="background-color: #ffff00; width: 100%; height: 15px; margin-bottom: 5px;"></div> <p>Medium (acceptable)</p>	<div style="background-color: #ff0000; width: 100%; height: 15px; margin-bottom: 5px;"></div> <p>High and Very High (unacceptable)</p>
---	---	---

Operations / Activities of the task execution process	Threat (occurring at various stages of the task execution process)	1	2	3	4	5	6	7	8
		Estimation		Risk (table) VS,S,M,H,VH	Risk reduction methods	Probability	Severity	Other risks (table) VS,S,M,H,VH	Responsible for implementing the agreed risk reduction methods (Name and surname)
		Probability	Severity						

Job safety analysis (JSA) - a documented analysis of specific work-related hazards and appropriate security measures that must be implemented to ensure safe execution of works. The mandatory elements of JSA are: task description, hazard identification, risk assessment, selection of safeguards (organizational measures, collective protection measures, personal protection equipment), description of the manner of performing the works (IBWR, BIOZ for works specified in the regulations).

Annex no. 17

Model of the Scaffolding Collection Protocol.

Wyciąg z protokołu odbiorowego nr:		
..... Nazwa wykonawcy rusztowania		
Nazwa użytkownika/użytkowników :		
Dopuszczalne obciążenie pomostu roboczego		
Data dopuszczenia do użytkowania:		
Data dokonanego przeglądu:	Data	Podpis
NAKAZ STOSOWANIA:		
	TAK	NIE
Uziemienie rusztowania		
Szelki i linka bezpieczeństwa		
Urządzenie samohamowne		
Lina asekuracji poziomej		
Wygradzenie terenu		
..... Data i podpis osoby dopuszczającej rusztowanie do użytkowania		
Numer telefonu komórkowego do wykonawcy rusztowania:		
Użytkownik rusztowania	Podpis	Telefon

Apparatus entrance card

Name of the Instalation/ Object:	Permit number:	Date of measurement	
Name of the apparatus:		Continuous measurement	YES/NO* <small>* Delete as appropriate</small>

Name and surname of the person taking the measurement:

Name and number of the measuring device:

Mark the necessity to perform analyzes and preparatory procedures in the appropriate box	TYES	INO	Measurements results										
			hour/ result	hour/ result	hour/ result	hour/ result	hour/ result	hour/ result	hour/ result	hour/ result	hour/ result	hour/ result	
Concentration of flammable or explosive gas vapors [under 10% LEL]													
Toxic gas concentration [%]													
Oxygen content [%]													
Temperature [°C]													
Others													
Plugs													
Voltage disconnected / disconnected PiA systems													
Pyrophoric compounds													
Neutralization													
Visual control													
Others													

In case of danger, stop work immediately and evacuate outside!

Annex no. 19**List and characteristics of hazardous materials in terms of explosiveness**

Flammable material			Flash-point	DGW		Relative density of gas or steam related to air)	Temperature of self-ignition	Explosive group	Temperature class	Number of the space in which the substance is present			
No.	Name	Composition					[°C]				[kg/m ³]	[% vol.]	[°C]
		[V/V]											
1	2	3	4	5	6	7	8	9	10	11			

Annex no. 20**List and classification of potentially explosive atmospheres**

No. of classified space	Name of classified space	The type of space	Classification of space
1	2	4	5

Note:

For existing facilities, having a complete, consistent with the actual state of the object, classification documentation for potentially explosive atmospheres, classification of workplaces in which explosive atmospheres may occur should be carried out taking into account the translation of zones hazardous of explosion according to subsequent ordinances on fire protection of buildings, other construction objects and areas you should assume the signs:

- zone 0** - for zone Z 0 and for zones of category W I, in which the explosive atmosphere occurs permanently or permanently under normal operating conditions;
- zone 1** - for zone Z 1 and for zones of category WI, in which the explosive atmosphere occurs periodically under normal operating conditions and zones of category W II, in which the explosive atmosphere may be prolonged;
- zone 2** - for zone Z 2 and for zones of category WII, in which the explosive atmosphere may occur only temporarily, and for zones of category W III;
- zone 20** - for zone Z 10 and for zones of category W IV;
- zone 21** - for zone Z 11 and zone W V, for which an explosive atmosphere in the form of a cloud of flammable dust in the air can sometimes occur during normal operation;
- zone 22** - for zone Z 11 and zone W V, for which an explosive atmosphere in the form of a cloud of flammable dust in the air does not occur during normal operation, and in case of occurrence it is short.

Annex no. 21a**The result of the explosion risk assessment**

Item	Identified explosive atmospheres			Identified potential sources of ignition		Risk of explosion		
	Name of classified space	The probability of an explosive atmosphere	Type of danger zone	Type	The probability of occurrence of an ignition source	P - probability of explosion (the product of columns 3 and 6)	S	R
1	2	3	4	5	6	7	8	9
1				Flames and hot gases				
				Electrical equipment (electrically generated sparks)				
				Static electricity				
				Thunder Strike				

Where: P - the probability of explosion as a product of the probability of the appearance of effective ignition sources and the occurrence of an explosive atmosphere

S - explosion effects determined on the basis of matrix from point 3.3. We accept the highest category designated for individual groups (Employees, Population, Environment, and Property).

R - explosion risk determined on the basis of the matrix from point 3.3.

Annex no. 22**List of potentially explosive workplaces**

Item	Workplace	The employee's business position	No. of space and type of explosion hazard zone	Risk of explosion
1	2	3	4	5

Note: In the column "Space number and type of explosion hazard zone", the possibility of occurrence of more than 1 classification card should be taken into account. In column 5, enter explosion risk estimated in pt. 3.3.

Annex no. 23**Specification of explosion-proof devices**

Data from the nameplate of the device					Classification data					Remarks measuring circuit numbers	Authorization opinion / signature
Item	Name and type of device	Manufacturer	Name of the certification body, certificate number	Explosion-proof device and ATEX marking	Type of Ex zone	Explosion group and temperature class	Workplace (open / closed space)	Quantity	Another certificate number (according to the list of attached certificates)		
1	2	3	4	5	6	7	8	9	10	11	12

Annex no. 24**List of certificates for explosion-proof devices**

Next consecutive number of the certificate	Certificate number	Feature of the device	ATEX marking	Manufacturer, name and type of device	EU declaration of conformity

Permit No.....

for the temporary location of the Contractor's facility (number records are kept by the Technical Infrastructure Department)

1.1. Company name*:

1.2 Type of back office *:
.....
(social, warehouse, assembly)

1.3 Basis / form of sharing / justification for the need to organize facilities *:
.....

.....
signature stamp of the Employer

1.4 Bringing the scope of the land reservation for the back office to the numerical map of the production plant in the Department of Geodetic and Cartographic Documentation.

.....
1.5 Opinion in the form of a reservation of the area of the Office of Spatial Information and Design Analysis:
.....

1.6 Opinion of the Water and Sewage Plant on the presence of underground infrastructure and the method of its protection ***:
.....
.....

1.7 Opinion of the IT Infrastructure Office on the presence of underground infrastructure: ***
.....

1.8 Opinion of the IT Infrastructure Office on the method of securing the underground infrastructure: ***
.....

1.9 The period of functioning of the back office *:
from the date of.....until.....

1.10 Location of the back office with the description of its area in the attached sketch:.....
.....

1.11 Number of objects (containers, etc.) set up in the area the subject facilities and their short characteristics *:
.....
.....
.....

1.12 Name and surname of the person responsible for compliance with the provisions in force in ORLEN S.A. use of facilities and telephone Contact *:

.....

1.13 I confirm that I am familiar with the Instruction on Handling the Location and Organization of Contractors' construction sites on the premises of the production Facility in Płock, PTA Facility in Włocławek, CCGT Włocławek Facility or adjacent areas and compliance with its provisions. **

1.14 I confirm the acceptance of the conditions set in the permit and compliance provisions of the Comprehensive Prevention System. **

.....

**Signature and stamp
Contractor**

.....

**Signature and stamp
Owner / Area user**

* - is completed by the Contractor

** - applies to the Contractor

*** - applies to the area along the road infrastructure and the periphery of the plots of production installations, where the underground infrastructure is located, e.g. main water and sewage pipelines

PROTOCOL
transfer of the back-up facility area

1. Contractor declares that he accepts the area located on the plot with area of (m²). intended for back-up facilities:
.....
2. Condition of the area (order/tidiness, disorder):
.....
.....
.....
.....
3. The Contractor declares that for the duration of the existence of the back-up he assumes responsibility for the state of cleanliness both at the back office and in its immediate vicinity.
4. The Contractor assumes responsibility for the proper management of municipal waste generated in the acquired back-up area and undertakes to ensure the collection of municipal waste on its own by signing a contract for the collection of selectively collected waste with an authorized company operating in a given area.
5. The Contractor (owner) of the back-up facilities is obligated to report to the Owner / User of the area within 3 days before the expiration date of the location liquidation of the facilities or request for extension of validity. Otherwise, ORLEN S.A. removes the facilities at the expense of the owner.

.....
Owner's signature and stamp

.....
Contractor's signature and stamp

Annex no. 27

Płock date

BACK-UP USER'S STATEMENT

declare that I have read the opinions and comments of the Owners of the underground and above-ground infrastructure on behalf of ORLEN SA regarding the location of the temporary facilities in the main lane.

At the same time, I declare that in the event of a failure and the related need to carry out repairs, I will remove the facilities immediately and at my own expense.

.....
Signature and stamp
Back-end user
(Contractor)

**LIQUIDATION OF THE
BASE / AREA / SITE / OF CONSTRUCTION ***

Contractor declares that as of (date) , the site located on a technology plot no. with area of (m²) intended for the location of temporary back-up facilities in an orderly / unstructured state *.

Description of the condition of the area:

.....
.....
.....

The Contractor declares that all elements of the overground utilities and underground area related to the Contractor's temporary back-up facilities have been removed / inventoried and contributed to the map of the General Plan *.

Confirmation in the form of cancellation of the reservation of the area of the Geodetic and Cartographic Documentation Team:

.....
.....

Handler:

Receiving Acceptance:

.....
Signature and stamp
Contractor

.....
Signature and stamp
Land Owner/User

Lack of acceptance of the land owner:

.....
Date, stamp and signature
Land Owner/User

Notes/comments:.....
.....
.....
.....

PROTOCOL

on the transfer of the construction site (for "fast track" tasks)

written down on the (day)..... by representatives:

a) on the part of the Investor providing:

.....
(name and surname - official position)
.....
(name and surname - official position)
.....
(name and surname - official position))

b) from the General Contractor:

.....
(name and surname - official position)
.....
(name and surname - official position)
.....
(name and surname - official position)

The subject of the transfer is an area of aboutm² (according to a situation plan)
bordering on

.....
.....
.....

1. The area described according to point 1 is a construction site for the following buildings:

.....
.....
.....

2. On the land handed over there are/ aren't following obstacles to demolition or embankments and pits, requiring equalization:

.....
.....

3. The following Investor facilities are located within the construction site

- A. the water intake point
- B. power point, energy and light.....
- C. the outlet point of the heating steam.....
- D. buildings
- E. roads for transporting materials

F. tracks and unloading points of wagons.....

G. underground infrastructure, e.g. main water and sewage pipelines

.....

H. underground telecommunications infrastructure, e.g. teletechnical cable wells,
telecommunications ducts, telecommunications cables

.....

Others:.....

.....

I. The remaining development of the construction site will take place by the Contractor
of the works based on the organization of works or other

arrangements:.....

.....

4. The investor transfers to the General Contractor buildings designated in the construction site

.....

.....

main axes of construction of the following facilities and technological devices:

.....

.....

The Investor provides the Contractor with the following permanent leveling points (Benchmark
(surveying)).....

.....

5. The Investor transfers to the Contractor:

a) Construction log.....

b) current sketch of obstacles confirmed by the Office of Investor Supervision and Support for
Property Investments existing on the construction site

.....

c) geodetic survey

d) technical documentation of the work carried out.....

.....

.....

e)others.....

.....

.....

6. The investor declares that on the transferred site there are/ are no gas devices, production
installations, pressure tanks, causing the following restriction in the use of open fire, performing
welding works and the use of flammable materials :

.....
.....
7. The General Contractor assumes responsibility for the proper management of municipal waste generated on the acquired construction site, including the back-up facilities, and undertakes to ensure the collection of municipal waste on its own by signing a contract for the collection of selectively collected waste with an authorized company operating in a given area.

8. The Contractor acquiring the construction site states that he took over the construction site within the period provided for in the contract (with delay of days) and to the extent enabling full performance of works with the following reservations:

.....
.....
.....

Signatures of the Investor's Ordering Party:

Signatures of the Contractor's representatives

.....
.....
.....
.....

.....
.....
.....
.....

This protocol is a whole with the following attachments:

- a) the construction log provided by the Investor,
- b) plan and situational sketches, in particular:
- c)
- d)

This protocol has been drawn up in copies, one of which for:

2 x Investor (property and supervision):
.....

1 x General Contractor:
.....

1 x Construction manager:
.....
.....
.....



One-off permit no

for radiological examinations by radiographic teams with cameras containing radioactive sources

- 1. The name of the company
2. Date of radiographic examination from(h). to(h).....
3. Research site:Plot number.....
Installation (name).....
Object (name).....
4. Type of apparatusserial number
5. Radioisotopeactivity on the day of research[Ci].
6. Radius of the controlled zone[m],exposure time [min]
7. Radiological protection supervisor during the tests

Contact number
Person conducting research IOR name/surname, PAA decision number
date and signature of ZIOR or the Head of the Company

I consent:

date:.....
Signature of ZIOR / Person replacing ZIOR / Person authorized by ZIOR ORLEN S.A.

- Attention!
1. In special cases, consent is given by the Head of the Central Production Coordination Department informing ZIOR about the issued permit.
2. The permit should have a sufficient number of copies: a copy for the gate at entry and exit, a copy of the permit should be attached to a one-off permit issued on the site.
3. Work in the vicinity of installations: HF Alkylolation, Asphalt Oxidation, Reforming V, Reforming VI, Gudron Hydrodesulphurization and Basell Orlen Polyolefins, at the PTA Plant (Production Department) and at the CCGT Wloclawek Plant must be preceded by reporting to the supervision of the above-mentioned installations and be agreed in a one-off permit to perform work obtained at the site.
4. 15 minutes before the start of radiographic works on the premises of the Production Plant in Plock, the Central Scheduling and Production Coordination Department should be informed by phone (24 256 50 11) about the commencement of the works.

ORLEN Ochrona Sp. z o.o. confirms:

Date of entry time date of departuretime.....

legible signature

legible signature

Annex no. 31

ORLEN S.A.

Type	Complex	
	Area	

Technical inspection card

Device name:

Place of installation:.....

2.1. REFERENCE DATA				
No inventory.	Technological no.	Manufacturing number	Archive reference – technical document	Construction year

Item	Review date	Scope of the review	Review results and recommendations	The date of the next review	Signature of the person performing the review

Seal of the Water & Wastewater Plant

**PERMISSION No.....
for water intake from the fire water network**

Collector
(Name of the organizational unit of ORLEN SA, Company)

The purpose of collection.....
(specify the purpose of the collection precisely)

Location.....
(number of the plot on which the hydrant is located, hydrant no.)

Connection method and other requirements
.....
.....

Period of collection, from (day)..... to (day).....,from (hour)..... to (hour)

Person responsible for water intake
(Name, Surname, Position, tel.no.) (Signature)

.....
(Name of the organizational unit or Company, telephone number)

The maximum hourly flow rate of water intake [m³/h]

The amount of water consumed for the duration of the permit [m³].....

No. MPK / /The data necessary to issue a VAT invoice for the financial charge for consumed water

.....
/ Signature of the person responsible for unit or responsible on behalf of the Company /

The recipient of the water intake is obliged to:

1. Execution of the water intake point strictly according to the given conditions by the Water & Wastewater Plant.
2. Immediate cessation of water collection, until further notice for every order of persons specified in § 8 of the Operational Regulation on the use of fire water network and marking and maintenance of hydrants at the Production Facility in Płock.
3. Immediate removal of damage and leaks at the water intake points.
4. Securing the hoses led through the road and the organization of water intake in accordance with the provisions in force in the technical standard "Rules for the use of overground hydrants for purposes not related to fire protection"
5. Using typical hoses and fittings for water intake. The devices must be technically efficient, undamaged and tight, ensuring safe intake of fire water, equipped with a pressure reducer in accordance with the requirements of the "Rules for the use of overground hydrants for purposes not related to fire protection"
6. Leading the water intake points to their original state immediately after the collection.
7. Reports of cessation of water collection to the Production Process Master of the Water Production Unit
8. Indicate the MPK number of the organizational unit of ORLEN S.A., and in the case of enterprises, companies, etc. the data necessary to issue a VAT invoice for the financial charge for consumed water.

CAUTION!

Periodically and without notification, the pressure in the fire water network may increase to 1.6 MPa. In this case ORLEN Spółka Akcyjna shall not be liable for any consequences resulting from this. It is obligated to use pressure reducers on hydrant connections in order to reduce the pressure in accordance with the "Rules for the use of overground hydrants for purposes not related to fire protection". The side making the request for the fire water intake is responsible for the pressure regulators and their efficiency and installation.

Distributor:

1. The recipient
2. ZBP
3. SWS

Water and Wastewater Plant

.....
(position and legible signature or signature and personal stamp)

Annex no. 33 "Fire protection"

PRINCIPLES ON EQUIPPING FACILITIES OF ORLEN S.A. IN HANDHELD FIREFIGHTING EQUIPMENT

1. Rules for equipping ORLEN SA buildings in handheld firefighting equipment.

1.1 The type, quantity and location of hand-held firefighting equipment for newly designed facilities is determined by a project agreed by an expert on fire safety and approved by the Head of the Company Fire Brigade, excluding petrol stations.

1.2 The type, quantity and location of hand-held firefighting equipment for existing facilities is specified in the Fire Safety Instruction prepared by an authorized person approved by the Head of the Company Fire Brigade, excluding petrol stations

2. General rules.

All Company's facilities should be equipped with hand-held firefighting equipment adapted to extinguishing these groups of fires that may occur in the facility.

A minimum of one unit of fire extinguishing agent mass 6 kg (in the case of powder extinguishers) or 5 kg (in the case of fire extinguishers), which should be:

- in fire zones PM with fire load density $Q_d > 500 \text{ MJ} / \text{m}^2$ and included in the hazard category people ZL I and ZL III - for every 250 m² area,
- in other fire zones, with the exception of zones classified as persons of danger category ZL IV - for every 500 m² of area,
- be equipped with a unit of equipment for every 30 engines,
- smoking rooms should be equipped with at least one fire-fighting equipment unit.

A minimum of one unit of fire-fighting means of hand-held firefighting equipment is fixed:

- 25 kg (in the case of powder extinguishers) or 20kg (in the case of fire extinguishers) located on the level "0",
 - 12 kg (in the case of powder extinguishers) or 5 kg (in the case of fire extinguishers) located on other levels,
- provided for production installations.

Each time it is necessary to consider equipping the production installations with the AP 250 powder aggregate. Quantity and location require the approval of the Head of the Company Fire Brigade.

General rules for the deployment of hand-held firefighting equipment:

- it should be placed in places easily accessible and visible.,
- in places not exposed to mechanical damage and the operation of heat sources,
- access to the equipment should be at least 1 m wide,
- the distance from any place where a person can stay, to the nearest fire extinguisher should not be more than 30 m.

In cubic objects, portable fire-fighting equipment should be located:

- at the entrances to buildings
- in stairwells
- at crossings and corridors
- when leaving the rooms outside,
- in multi-story facilities, the equipment should be placed in the same places on each floor, if the existing conditions allow it,

On production installations, handheld fire-fighting equipment should be located:

- in places protected against adverse weather conditions,
- in the vicinity of places constituting from the technological point of view the greatest fire hazard,
- at technological levels (shelves) equipment should be placed in the same places at each level, if the existing conditions allow it.

3. Detailed rules for equipping technological facilities with handheld fire-fighting equipment

3.1.1. Drain and drain fronts.

- a) to secure railway fronts for filling and drainage - 1 portable fire extinguisher 25 kg with powder adapted to extinguish the group of ABC fires for each 25 m loaded loading or unloading railway front,
- b) to secure car tankers - 1 portable fire extinguisher 50 kg (or 2 portable fire extinguishers 25 kg each) and 2 powder fire extinguishers 6 kg with powder suitable for extinguishing ABC fire groups, for each pourer,
- c) in the case of electric motors, in addition - two CO₂ fire extinguishers min. 5 kg suitable for extinguishing BC fire groups for every 5 electric motors started,

3.1.2. Pumping stations and filling rooms for petroleum products.

a) in the pumping station rooms and filling of liquid I and II class, it is necessary to ensure:

- one portable fire extinguisher 50 kg for every 300 m²,
- one 6 kg powder extinguisher for every 100 m²,
- in the case of electric devices or motors - according to 3.1.1.c.

3.1.3. Parking stands for road tankers.

- a) 1 portable fire extinguisher 50 kg (ABC) for every 10 parking stands started,
- b) 2 powder extinguishers 12 kg (ABC) for each 5 parking stands started,

3.1.4. Open landfills in unit packaging.

- a) one portable fire extinguisher 50 kg for each 600 sq m of landfilled area,
- b) 2 powder fire extinguishers min. 12 kg, for each 300 sq m of landfill site.

3.1.5. Other construction objects

- a) Vapor recovery installation - one 50 kg transport fire extinguisher and one 6 kg powder extinguisher,
- b) the product receiving node from a long-distance pipeline (including cleaning chambers) - one 50 kg transport fire extinguisher and two 6 kg powder fire extinguishers,
- c) devices and installations constituting nodes of sewage treatment plants - 1 portable fire extinguisher 50 kg and 1 powder extinguisher 6 kg.

3.1.6. Motor vehicles

Every vehicle used in the ORLEN S.A. it must be equipped with one powder extinguisher (ABC) with a minimum weight of 1 kg. Vehicles equipped with additional equipment (eg cranes, excavators, etc.) should have a second unit of firefighting equipment with a minimum weight of 6 kg designed to protect this equipment.

Vehicles intended for the carriage of dangerous goods shall be equipped in accordance with the ADR Agreement with the following handheld fire-fighting equipment:

Allowed total weight of the transport unit	The minimum number of fire extinguishers	Minimum total capacity per transport unit	Fire extinguisher to extinguish engine or cabin fire. At least one with a minimum capacity:	Requirements for an additional fire extinguisher. At least one fire extinguisher shall have a minimum capacity:
≤ 3,5 tons	2	4kg	2kg	2kg
> 3,5 tons ≤7,5 tons	2	8kg	2kg	6kg
>7,5 tons	2	12kg	2kg	6kg
The volumes refer to the extinguishing powder (or the equivalent volume of other appropriate extinguishing agents).				

3.1.7. Forklifts

Forklifts, regardless of the type of drive, must be equipped with a minimum of one powder extinguisher (ABC) with a minimum extinguishing agent weight of 4 kg.

4. Marking of the location of handheld firefighting equipment.





The location of handheld firefighting equipment should be marked in accordance with the applicable standard. The signs must have a CNBOP approval certificate and photoluminescent features. The marks should be placed in such a way as to ensure their maximum visibility, and if the marking of the location of the handheld firefighting equipment is poorly visible, it is reasonable to consider the marking eg from two sides.

5. Final remarks.

The above quantities of handheld firefighting equipment are minimum quantities. If there is a need to provide fire-fighting equipment of objects other than the aforementioned type, the quantity and location of hand-held fire-fighting equipment is accepted by the Head of the Company Fire Brigade based on the documents referred to in point 1.

Fire extinguishers shall be provided with a seal confirming that they have not been used. In order to ensure the correct operation of fire extinguishers, they should be subject to technical inspections and maintenance operations in accordance with the applicable national standards. They should be marked with a mark of compliance with a standard recognized by the competent authority and with a sign indicating the date of the next inspection.

The size of the characters should have at least:

GRAPHIC SYMBOL	NAME OF THE SIGN	DIMENSION (production installation)	DIMENSION (other objects)
	<p>FIRE EXTINGUISHER</p>	<p>400x400 mm</p>	<p>100x100 mm</p>
	<p>TRANSPORTABLE EXTINGUISHER</p>	<p>400x400 mm</p>	<p>150x150 mm</p>
	<p>FIRE PROTECTION EQUIPMENT</p>	<p>400x400 mm</p>	<p>150x150 mm</p>
	<p>FIRE BLANKET</p>	<p>400x400 mm</p>	<p>150x150 mm</p>

**DECLARATION OF THE OHS COVERAGE OF THE COMPANY ACCESSING WORKS
ON THE AREA OF ORLEN SA**

NOTE: Please fill out the following boxes according to the actual situation in your company. The data can be verified by the employees of the HSE services of ORLEN SA and ORLEN Eko

I. Basic information

I.A Name of the Company

I.B Adres of the Company

I.C Total employment in your company (at the end of last month)

I.D The number of employees foreseen for the implementation of the task for
ORLEN SA

I.E Contact persons in connection with the task

1 Name, surname and function	phone.:	, e-mail:
2. Name, surname and function	phone.:	, e-mail:

I.F. Contact information for the health and safety officer or the head of the occupational safety and health department or data of an external company supervising health and safety at work for ORLEN SA

1. Name, surname and function	phone:	, e-mail:
-------------------------------	--------	-----------

I.G The name of the bidding

I.H. The main work that will be carried out by your company on the premises of ORLEN SA:

1.
2.
3.
4.
5.

I.I. Has your company performed previous work in the area?

II. Health and safety documentation and employee training

II.A. Does your company have a Safety Management System?

II.B. Does the Safety Management System have a certificate?

II.C. The total number of internal written safety procedures / instructions

II.C. Do employees have current OHS training?

preliminary

workplace

periodic (manual workers)

Appendix no. 4 to the General Safety Requirements – Guidelines No. 2

periodic (persons directing the employee)

II.D The number of employees planned for the task at ORLEN SA with a completed first aid course

II.E. Has Occupational Risk Assessment (ORZ) been developed for all workplaces in your company?

II.F. Are health and safety inspections carried out at work sites in the company?

II.G. Does the company keep a record of post-audit reports?

III. Statystyka wypadków

III.A. Please fill in the table below, taking into account the last 3 years

Year	Number of accidents			Accident frequency indicator
	deadly	Heavy	Light	

* calculation index according to the following formula:

$$\text{Accident frequency indicator} = \frac{\text{total number of accidents}}{\text{the total number of man-hours worked during the year}} \times 1\,000\,000$$

III.B. Does your company keep a record of non-injury events?

III.B.1. Number of non-injury events registered last year

III.C. Does your company keep a register of potentially accidental events?

III.C.1. Number of potentially accidental events registered in the previous year

IV. Periodic examinations

IV.A Do employees have current medical examinations?

preliminary

periodic

specialistic

IV.C. How many cases of occupational diseases have been reported in your company over the last 5 years?

V. Administrative decisions

V.A. Please fill in the table below regarding administrative decisions addressed to your company, taking into account the last 5 years

Year	Issued decisions			
	PIP	PSP	WIOŚ	Sanepid

--	--	--	--	--

Appendix no. 4 to the General Safety Requirements – Guidelines No. 2

V.B. Number of court cases against your company in connection with accidents at work

V.C Number of post-accident proceedings in your company carried out with the participation of PIP and the Prosecutor's Office

V.D Number of equipment subject to the provisions of the Technical Supervision and the task to be performed at the premises of ORLEN SA (cranes, forklifts, lifts, cylinders with technical gases, etc.)

V.E. Do all devices subject to the UDT have the required documentation and permitting decisions?

VI. Personal protection and protective equipment

VI.A. Does your company declare that all employees foreseen for work on the premises of ORLEN SA have adequate amount of protective clothing and footwear, including antielectrostatic properties, helmets, gloves and safety goggles, hearing protectors, protective helmets, dust masks, gas masks or escape hoods, safety equipment before falling from a height, etc.?

VI.B. Does your company declare to show the required approvals / certificates and inspection and maintenance protocols for machinery, equipment and protective equipment?

VI.C. Does your company declare equipping workplaces with its own, technically operable, handheld firefighting equipment? (fire extinguishers, extinguishing units, blankets)

.....

Person responsible for completing the "OSH Declaration"

Name and surname:

Position:

Phone No.:

E-mail:

Date and place of completion:

.....

Company's stamp

.....
(stamp of the
Contractor / Subcontractor)

No.

ORLEN S.A.
ul. Chemików 7
09-411 Płock
Group OHS and Prevention
Coordination Department

APPLICATION

for training on health and safety hazards, fire hazards and chemical hazards for employees of external Contractor providing works on the premises of ORLEN S.A.

In connection with the implementation of Agreement No.....
for the task titled

.....
please conduct a training on hazards on (date/time) for persons listed below:

Item	Name and surname	Name of the Contractor / Subcontractor Enter the name of the Company in which the person referred for training is actually employed	Status PW – Contractor's employee ¹⁾ NP – not an employee ²⁾ PP – Subcontractor's employee ¹⁾	Type of contract in the case of persons employed on a basis other than an employment contract

¹⁾ A person employed under an employment contract. ²⁾ A person employed on a basis other than an employment contract (eg contract for specific work; mandatory contract).

.....
(date)

.....
(stamp and signature of the applicant)

Confirmation of the implementation of said Agreement

Person responsible from the Procurement Office, Investment Office or the Technology Office depending on the type of Agreement.

.....
(Name and surname, date, stamp and signature)

.....
(Name and surname, date, stamp and signature)

Decision: I consent / do not consent* to the training on (date)

Person managing the Group OHS and Prevention Coordination Department or an authorized person

*) – delete if not applicable

.....
(date, stamp, signature)

Participation in the training only in private clothes and shoes (people in working clothes will not be allowed into the training room).

Instruction

Extract from the Instruction on the rules, organization and control of OHS and fire safety training and conducting workplace training at the ORLEN S.A. constituting Annex No. 1 to the Regulation on this matter.

I. Training for employees of another employer performing work on the premises of ORLEN S.A.

1. The aim of the training is to provide information on health and safety hazards, fire hazards and chemical hazards for employees of external Contractor providing works on the premises of ORLEN S.A..
2. This training is provided by OHS Specialists and Fire Safety Specialists of ORLEN S.A. at the request of the Contractor of works for ORLEN S.A. and its Subcontractors.
3. Employees of external Contractor providing works on the premises of ORLEN S.A., receive a referral for OHS training on hazards to the Group OHS and Prevention Coordination Department from the Ordering Party.
4. Training on the hazards occurring at the Production Facility in Płock, PTA Facility in Włocławek and the CCGT Facility in Włocławek is conducted on Monday, Wednesday and Friday outside the PF in Płock, in the OHS Office building – room no. 4a (if they are not statutory days free from work). The training starts at 8:00 (**on Wednesdays – at 10:00**) and lasts 2 hours.
5. Training on the hazards occurring at the Production Facility in Płock, PTA Facility in Włocławek and the CCGT Facility in Włocławek for foreigners will take place after receiving a referral for training confirmed by the Control and Security Office to the Group OHS and Prevention Coordination Department from the Ordering Party and individual arrangement of the training date.
6. Date of the training for employees hired outside the Production Facility in Płock, PTA Facility in Włocławek and the CCGT Facility in Włocławek is determined by the managers of the organizational units with employees of ORLEN Eko Sp. z o.o.
 - 6.1 Completion of the training on hazards is noted in the “Certificate for employees of other employers, conducting works on the premises of ORLEN S.A.”. **The training is valid for 1 year. For foreigners, it's possible to obtain translated version of the document.**

II. Procedure for Contractors having signed contracts with ORLEN S.A.

1. **Complete the Application by entering the required data and information.** If you do not enter the required data in the table, the Application will be returned to the Applicant in order to complete it.
2. **Obtain confirmation of the implementation of the Agreement.** Without the confirmation, the Application will be returned to the Applicant for completion. For Subcontractors, obtain the signature of the Contractor for whom the Subcontractor will work and of the representative of ORLEN, who will confirm the fact of concluding the Agreement with the Contractor.
3. **Provide in person a completed Application to the Group OHS and Prevention Coordination Department** (OHS Office building near Gate No. 1 of the Production Facility in Płock - room 14) or by e-mail to szkoleniabhp@orlen.pl
4. **Determine with the training coordinator whether there are any vacancies within the indicated date specified in the application** – in person in the OHS Office building near Gate No. 1 of the Production Facility in Płock - room 10; or by telephone at 24 286 84 22.

Attention!

1. The training on hazards may only be attended by persons on the basis of a correctly prepared Application. **Participation in the training only in private clothing and footwear** (people in work clothes will not be allowed into the training room).
2. In case of any questions or doubts, the information is provided every workday from 8:00 to 14:00 by phone at 24 286 84 22 or in person at the OHS Office building near Gate No. 1 of the Production Facility in Płock - room 14.
3. Training on hazards conducted in the Group OHS and Prevention Coordination Department is **free of charge**.
4. Providing non-compliant data in the table is punishable by an additional penalty specified in the Agreement.

EXAMPLE – INSTRUCTIONS DEFINING THE DETAILED CONDITIONS FOR THE SAFE CONDUCT OF WORK ON THE INSTALLATION AREA PREPARED FOR THE ISSUED LONG-TERM PERMIT

1. PURPOSE

In order to ensure safe organization and implementation of works, the procedure for issuing Daily Cards - one-off permits for works to a long-term permit for investment works during the renovation / technological shutdown of the Installation in 20 ... is introduced.

The instruction defines the procedure and rules for issuing permits for works, including particularly hazardous works.

2. SCOPE OF APPLICATION

The instruction is valid in connection with obtaining a long-term permit for investment works issued by ORLEN S.A. in connection with the maintenance shutdown of the installation within the time limit The Instruction sets out the detailed conditions for safe performance of work on the site of the installation is also known as the Instructions for safe work implementation (IBRP) and a Daily Card – one-off permit is issued for it - in accordance with the form set out in Annex A to these Instructions.

Works in tanks, apparatuses, closed spaces and works in sewage manholes, earthworks and the first opening of pipeline apparatuses will be performed on the basis of one-off permits for particularly hazardous works issued by Orlen S.A.

3. LIABILITY

All employees and their superiors performing works on the basis of the Daily Card – one-off permit to the long-term investment permit issued by ORLEN, to the extent applicable to them, are responsible for compliance with the provisions of the Instructions.

4. DEFINITIONS

Terms used in these "Instructions" mean:

4.1 „Questionnaire preparing the Contractor for particularly hazardous works” – a checklist allowing to assess the preparation of the Contractor / executive team to perform a specific particularly hazardous work, conditioning the issue of a permit, and also constituting an appendix to the daily card - a one-off permit and archived together with them in the Consortium unit issuing the permit (to be filled in by the Contractor in one copy before starting the work) - Appendix B / 1

4.2. „**Name list of the employees of the executive team**” – a list containing the names and surnames of employees and the numbers of their access cards, signed and delivered by the Contractor in one copy to the cell issuing the permit. The list will be attached and archived together with the permit – Appendix B / 2.

4.3. „**Belayer on the part of the Contractor**” – a designated employee on the part of the Contractor who supervises the works and has current periodic health and safety training for persons managing employees.

4.4. „**Instructions for safe work implementation (IBRP)**” – instructions prepared for the implementation, for more than one day, of the same particularly hazardous works and other works, containing the same substantive scope as one-off permits and fulfilling the same role as permits.

4.5. „**Contractor**” – a designated employee on the part of the Contractor, e.g. foreman, deputy foreman, lead fitter, i.e. a person supervising employees, having a valid certificate of completion of periodic health and safety training at the level of persons managing employees. A person authorized to collect one-off permits.

4.5. „**Approver**” - Project implementation manager, a person with OHS training for senior management approving the Daily Card –one-off permit, in accordance with the provided contact list.

4.6. „**Confirmation of the performance of the analytical control**” – employee of ORLEN, supervisor of the renovated installation, eg Master of production processes - shift manager or junior master of production processes.

- 4.7. „**Work at heights**” – work carried out on a surface located at least 1.0 m above the floor or ground.
- ✓ Work at height does not include work on the surface, irrespective of the height at which it is located, if such a surface: is covered on all sides, up to a height of at least 1.5 m, with full walls or walls with glazed windows, is equipped with other fixed structures (e.g. fixed, barred platforms) or devices to prevent the worker from falling from a height (legal basis: § 105 ust. 1 i 2 Regulations of the Minister of Labor and Social Policy of September 26, 1997 on general provisions on health and safety at work - uniform text: Dz. U. z 2003 r., nr 169, poz. 1650 as amended).

Works carried out at a level above 1 m, on all types of scaffolding (including system scaffolding), within the meaning of the above regulations, are WORKS AT HEIGHT.

- 4.8. „**Work using hazardous materials**” – in particular, work with hazardous substances or mixtures and with materials containing harmful biological agents classified to the 3rd or 4th hazard group in accordance with the regulations issued on the basis of Art. 2221 § 3 of the Labor Code.

- 4.9. „**Work with open fire**” – Carrying out activities where sparking, incandescence or burning of the material occurs or may occur. Typical examples are: welding, annealing, heating or burning with a flame, grinding, sparking of tools, electrical devices - e.g. electric wrenches without Ex protection, work with motor vehicles, work with tools with rotating parts driven by combustion or electric motors, e.g. brushcutters, compactors, saws etc.

- ✓ The system for issuing Daily Cards - one-off permits is valid if the Investor issues a long-term permit for investment works.
- ✓ A permit to perform works is issued only for works carried out on the premises of the renovated installation for which a long-term permit is valid.

After the introduction of the overhaul mode on the renovated installation, works can be carried out on the basis of a long-term permit and from then on, work at height, work with open fire, work with hazardous substances, and work on power equipment are carried out on the basis of this manual. If it is possible, at the moment of introducing the overhaul mode, the supervision of the installation will provide a report on the analyzes performed after the installationhas been stopped.

- 4.10. „**Suspension of work**” – revocation of a written permit to perform work in connection with an emergency situation that creates an accident hazard or a gross violation of the applicable provisions and rules of occupational health and safety and fire protection by persons related to the work performed.

- 4.11. „**Executive team**” – a group of a maximum of 25 employees performing the work specified in the Daily Card - a one-off permit, ensuring the possibility of full supervision by the Contractor and additional security by the Contractor. For particularly hazardous works, 1 supervisor should be provided for every 10 employees.

It is not required to issue a written permit for activities related to saving people during rescue and firefighting activities. In this case, the head of the Rescue Operation is responsible for the selection of protective measures.

- 4.12. If the planned manner of performing works directly threatens the health and life of the employees who perform it or third parties, or the prevailing technical and organizational conditions do not allow for safe performance of the work, Approver have the right to refuse to issue a permit until the existing obstacles are removed (Article 210 of the Labor Code).

- 4.11 If the Contractor determines that the safety conditions specified in the Daily Card - one-off permit are not sufficient to safely perform the work and directly threaten the health and life of the employees or third parties, or the permit is illegible, it may refuse to accept the Daily Card - one-off permit or refrain from performing work (Article 210 of the Labor Code).

5. COURSE OF THE PROCEDURE

- 5.1 The system for issuing Daily Cards - one-off permits is valid if the Investor issues a long-term permit.
5.2 The work permit is issued only for works carried out on the premises of the renovated installation, for which a long-term permit is valid.

6. PROCEDURE FOR ISSUING AND RECORDING DAILY CARDS - ONE-OFF PERMITS FOR WORK

- 6.1. A specific person / persons will be appointed and authorized to issue daily cards - one-off permits. Persons collecting the permit (with training for persons managing employees, foreman, deputy foreman) at the end of the working shift by/ until "order" permits for the next day, specifying the expected number of employees (at the person appointed to issue the Daily Card – one-off permits)

Daily card - a one-off permit is issued in three copies for the purpose:

- 1 copy – The person issuing the permit,
- 1 copy – Contractor - The person collecting the permit,
- 1 copy – The person responsible for a given renovation section on the part of ORLEN.

Persons collecting the Daily Card - one-off permit are also required to go to the Master of the renovated installation and make entries in the "Next Day Work Book" regarding the workplace, scope of work, number of working employees who will perform work on the next day. The information must be submitted by...../..... The maintenance section operator on the part of ORLEN will use this data to coordinate the works carried out on the section / installation. In the event of circumstances preventing the commencement of works, the coordinating party shall provide information about the impossibility of commencing works or about suspending them.

Before the commencement of work on a given shift for long-term permits, a table will be prepared by the installation supervision by ORLEN in accordance with the following example - Table No. 1:

No.	Date	Company	Scope of works, tech. number of the apparatus / pipeline on which the works with open fire are carried out	The number of people carrying out the work	Surname/first name (Contractor)	Signature (Contractor)	Name and surname of the person responsible for site preparation and inspection	Signature	Signature of the shift manager responsible for the renovation area
1	2	3	4	5	6	7	8	9	10

The data contained in Table 1 indicate the need for an analytical control by Orlen (explosiveness, toxicity). The performed analytical checks on a given installation / renovation section will be marked on a map, confirmed by the Master of Orlen, then sent to the person issuing the daily cards - one-off permits by the deadline of each day until Providing the person issuing the daily cards - one-off permits with information by the Master of production processes - shift manager or Junior Master of production processes, Orlen clearly indicates that there are no contraindications to perform work on the renovated installation and will be a consent to the issue of daily cards - one-off permits and the commencement of works by the Contractor.

Persons collecting daily cards - one-off permits (with training for people managing employees, foreman, deputy foreman, lead fitter) at (hour) / will bring Appendix no. B / 2 "Name list of employees of the executive team" to the person issuing the daily card - one-off permit.

On this basis, the person issuing the permit updates the composition of the employees in the executive team. Until (hour) / the person issuing the permit provides the designated employee of Orlen with one copy of the Daily Card - a one-off permit.

At the Contractor's request, Orlen will additionally perform an analytical control at the indicated location. Please specify exactly on the authorization form:

1. Sequence number.
2. The name of the company or the name and surname of the person performing the work.
3. In point I - the type of work performed by putting an "X" in the appropriate box.
4. In point II - valid on - date, estimated time of commencement and completion of work (this is the period of validity of the permit)
5. In point III - workplace - the exact location of the workplace, taking into account: installation, plot, node, apparatus number (if any), pipeline, equipment, level of work, flyover, etc.
6. In point IV - scope and type of work - scope of work, equipment used. In the event of the necessity of the entry and operation of heavy equipment, the entry "movement of the device in limited space conditions" should be included.
7. In point V - the predictable size of the team performing the work (max 25).

It is accepted as a rule that the Contractor (the person collecting the Daily Card - one-off permit for particularly hazardous works) delivers the signed "Name list of the executive team employees"

(Contractors and Subcontractors) containing the names and surnames and numbers of access cards of all employees before signing the permit. (Annex B/2).

8. In point VI - existing and anticipated hazards - the nature and type of threats (from the renovated device, its surroundings, neighboring objects) (pictograms).
9. In point VII - preparation and protection of the workplace - Appropriate activities should be selected by placing an "X" in the YES or NO box..
10. In point VIII - protective measures:
 - ✓ belaying, security posts - specify the type of belaying or security post by putting the "X" sign in the appropriate box, and also specify the frequency of periodic belaying and designate the persons providing it in point X.
 - ✓ protective equipment and clothing - types of protective clothing and personal protective equipment necessary for the safe performance of work in terms of existing and anticipated hazards (e.g. protective clothing (i.e. other than required by general regulations, e.g. welding aprons), dust masks, escape equipment, chemically sealed goggles, face shields, hearing protectors, buzzer, multi-gas detector, safety harness, self-locking device, safety shock absorber, safety line and others) by putting an "X" in the appropriate box and specifying the type of protective clothing. The Contractor is responsible for the use of the equipment specified in the permit.
 - ✓ fire protection - handheld firefighting equipment - type and quantity of portable handheld firefighting equipment to secure the workplace, or other forms of protection, e.g. a fire blanket, spraying with water and others, by putting an "X" in the appropriate box.
 - ✓ other - instruction for the Contractor - if required.

The results of the analyzes should be archived for 3 years together with the issued daily cards - one-off permits.

7. RESPONSIBILITIES

7.1 The UNIT issuing the permit is responsible for:

- ✓ correct completion of the Daily Card - one-off permit in accordance with the information provided by the Contractor,
- ✓ archiving of issued Daily Card - one-off permits,
- ✓ keeping records of Daily Card - one-off permits,
- ✓ control of the number of reported employees,
- ✓ delivery of Daily Card - one-off permits from a designated employee of Orlen S.A.,
- ✓ keeping lists on the number of people present in the installation / section.

7.2. THE APPROVER (Project Manager) of daily card - one-off permits to perform the work is responsible for:

- ✓ decision to issue a daily card - one-off permit,
- ✓ decision to start work,
- ✓ random control of the implementation of works,
- ✓ immediate suspension of works, in the event of discovering or receiving information about the emergencies that reduce the level of safe performance of work specified in the permit or gross violation of the applicable provisions and principles of occupational health and safety and fire protection.

7.3. The CONTRACTOR (foreman, deputy foreman, i.e. a person supervising employees, having a valid certificate of completion of periodic health and safety training at the level of persons managing employees.

A person authorized to collect one-off permits.) is responsible for:

- ✓ application of all safety measures specified in the daily card - one-off permit,
- ✓ conducting training for subordinate employees in the scope of existing or anticipated hazards during the works performed,
- ✓ filling the "Contractor's preparation for work questionnaire" and the implementation of all the safety measures recommended by the daily card – one-off permit,
- ✓ control and supervision of the safety of works and their immediate suspension in the event of an emergency and other conditions that reduce the degree of safe performance of the work specified in the permit or gross violation of the applicable provisions and principles of occupational health and safety and fire protection,
- ✓ inspection of the workplace after the end of work and applying its results in point XII of the issued Daily Card - one-off permit.

7.4 BELAYER:

- ✓ control and supervision over the safety of the works carried out,
- ✓ visual inspection of the work site,
- ✓ control of compliance with the regulations and safety conditions specified in the daily card - one-off permit,
- ✓ immediate suspension of works in the event of emergencies or non-compliance with the regulations or safety conditions specified in the daily card - one-off permit,
- ✓ an oral confirmation by the Contractor of the execution of point VII ÷ IX of the daily card - one-off permit.
- ✓ The person providing the permanent belaying remains in constant visual contact with the team(s) performing the work so that at any time he or she is able to visually inspect the work site and ensure their safe implementation.

7.5. Additional obligations of the Belayer (periodically) on the part of the Contractor - (Site Manager, Master):

- ✓ decision on how to perform the work,
- ✓ agreeing the terms of work with the necessary persons.

Attachments:

A. Daily card - one-off permit

B/1 Contractor questionnaire

B/2 Name list of the employees of the executive team

C. Records of daily cards – one-off work permits



DAILY CARD – ONE-OFF PERMIT NO

to perform particularly hazardous works

for

[Redacted Contractor Name]

(Contractor)

(stamp (name) of the issuing unit)

I.

- Work with open fire
- Work on power devices
- Work with UTB (crans, lifts)

- Work on heights
- Work with the use of hazardous materials
- Other works

II.

- Valid (date)

[Redacted Date]

- from (hour)

[Redacted Start Hour]

- to (hour)

[Redacted End Hour]

extended to (hour)

(stamp, signature)

III.

- **Workplace**
(specify exactly)

- installation, plot
- junction
- apparatus
- level
- overpass
- mogul
- other

IV.

- **Scope and kind of work**
(specify precisely)

scope of work

equipment used

It is allowed to carry out works inside an apparatus without equipment for protection of respiratory tract

YES NO

Contractor is obliged to tidy up the Site after completion of works.























V.

- **Number of persons in the team performing work:**

[Redacted Number of Persons]

Employees *(no more than 25 Employees)*

VI. Anticipated risks (specify precisely)

 MECHANICAL TRANSPORT <input type="checkbox"/>	 HOT SURFACES <input type="checkbox"/>	 VERTICAL TRANSPORT <input type="checkbox"/>	 RISK OF FALLING <input type="checkbox"/>	 RISK OF TRIPPING <input type="checkbox"/>	 FALLING OBJECTS <input type="checkbox"/>
 EARTHWORKS <input type="checkbox"/>	 DUST HAZARD <input type="checkbox"/>	 SHARP OBJECTS <input type="checkbox"/>	 EXPLOSION <input type="checkbox"/>	 NOISE <input type="checkbox"/>	 VIBRATIONS <input type="checkbox"/>
 CRUSHING CAPTURE <input type="checkbox"/>	 POSSIBLE HEAD INJURY <input type="checkbox"/>	 HAZARDOUS SUBSTANCES AND GASES <input type="checkbox"/>	 FIRE HAZARDS <input type="checkbox"/>	 WEATHER CONDITIONS <input type="checkbox"/>	 WELDING WORKS <input type="checkbox"/>
 ABOVEGROUND/ UNDERGROUND INSTALLATIONS <input type="checkbox"/>	 ELECTRIC SHOCK <input type="checkbox"/>	 CHOKING HAZARD <input type="checkbox"/>	 SPRAY/SPLINTER <input type="checkbox"/>	OTHER.....	

VII. Preparation and securing of the work site (specify precisely)

YES / NO

YES/NO

- | | | | |
|---|---|--|---|
| • protection against spattering sparks | <input type="checkbox"/> <input type="checkbox"/> | • preparation of scaffolding | <input type="checkbox"/> <input type="checkbox"/> |
| • fencing off the danger zone | <input type="checkbox"/> <input type="checkbox"/> | • sprinkling with water | <input type="checkbox"/> <input type="checkbox"/> |
| • posting warning notices | <input type="checkbox"/> <input type="checkbox"/> | • appointment of a rigger / whistleblower | <input type="checkbox"/> <input type="checkbox"/> |
| • execution of covers, curtains | <input type="checkbox"/> <input type="checkbox"/> | • protection of flammable materials | <input type="checkbox"/> <input type="checkbox"/> |
| • checking the protection of drain grates and sewage chambers within a radius of 20 m | <input type="checkbox"/> <input type="checkbox"/> | • lighting construction | <input type="checkbox"/> <input type="checkbox"/> |
| • other | | • additional protection when moving the load | <input type="checkbox"/> <input type="checkbox"/> |

VIII. Protective measures

1. Safeguarding / safety posts,

permanent Contractor,
periodic installation, fire brigade frequency, every h.
 other _____

2. Protective equipment and clothes – **as a standard: anti-static clothes and footwear, anti-splinter helmet and glasses, protective gloves.**
- | | | |
|--|--|--|
| <input type="checkbox"/> dust masks | <input type="checkbox"/> hearing protectors | <input type="checkbox"/> safeguarding rope |
| <input type="checkbox"/> gas masks | <input type="checkbox"/> safety harness | <input type="checkbox"/> fresh air apparatus |
| <input type="checkbox"/> chemical-sealed goggles | <input type="checkbox"/> retractable device | <input type="checkbox"/> acoustic signaling device |
| <input type="checkbox"/> face shields | <input type="checkbox"/> safety shock-absorber | <input type="checkbox"/> breathing apparatus |
- other _____

3. Fire protection – handheld equipment (*Contractor shall be responsible for application of relevant equipment*).
- | | | |
|---|---------------------------------|---------------------------------------|
| Portable equipment (fire-extinguisher): | Mobile equipment (unit): | Additionally: |
| <input type="checkbox"/> snow min. 5 kg szt. | <input type="checkbox"/> snow | <input type="checkbox"/> fire blanket |
| <input type="checkbox"/> powder min 6 kg szt. | <input type="checkbox"/> powder | <input type="checkbox"/> sprinkling |
- other _____

4. Analytical control
 required – renovation mode not required
5. Other **YES / NO**
 • training for the Contractor
 • other _____

IX. Arrangements
 It was agreed with _____

 in terms of _____

X. Persons related to the implementation

1. **I acknowledge and adhere to the points I – IX:**
- | | |
|---|---|
| Permanent belaying on the part of the Contractor - the person managing the employees | Permanent belaying on the part of the Contractor - the person managing the employees |
| _____
Name/surname Legible signature | _____
Name/surname Legible signature |

2. Analytical control. I confirm that the analyzes were performed in the scope of the renovation mode

 Name/surname Legible signature
3. **Contractor (the person managing the employees). I accepted and comply with the points I – X.**

 Name/surname Legible signature

XII. APPROVED (Project Implementation Manager)

 date Stamp, signature

XIII. Control after completion of works – performed by the Contractor or the Belayer in the presence of a representative of ORLEN.

The place of work was inspected. As a result of the inspection it was found:

Re-inspection / recommendations

XIV. • **Statement of completion of work.** The works were completed at

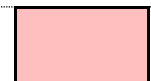

.....
Legible signature
Contractor/ Belayer

.....
Legible signature
ORLEN S.A.

XV. • **Attachments**

1.
.....

QUESTIONNAIRE
preparing the Contractor for particularly hazardous works

(completed by the Contractor)

RESPONSIBILITY = SAFETY

DANGER = INTERRUPTION OF WORK

Contractor's first and last name

Permit no

Date

What threads?

YES NO ABSENT

- | | | | |
|--|--------------------------|--------------------------|--------------------------|
| Has the Contractor been instructed about the expected and existing hazards during the work included in the permit | <input type="checkbox"/> | <input type="checkbox"/> | <input type="checkbox"/> |
| Have the employees been instructed by the Contractor about the expected and existing hazards during the work included in the permit? | <input type="checkbox"/> | <input type="checkbox"/> | <input type="checkbox"/> |
| Do the works carried out do not pose a threat to other people and the contractors themselves? | <input type="checkbox"/> | <input type="checkbox"/> | <input type="checkbox"/> |
| Does the Contractor have adequate and efficient personal protective equipment? | <input type="checkbox"/> | <input type="checkbox"/> | <input type="checkbox"/> |
| Does the Contractor have adequate and efficient safety equipment? | <input type="checkbox"/> | <input type="checkbox"/> | <input type="checkbox"/> |
| Does the Contractor have technically sound tools and devices? | <input type="checkbox"/> | <input type="checkbox"/> | <input type="checkbox"/> |
| Do the scaffolding require a design? | <input type="checkbox"/> | <input type="checkbox"/> | <input type="checkbox"/> |
| Are the scaffoldings properly positioned and have an important overview? | <input type="checkbox"/> | <input type="checkbox"/> | <input type="checkbox"/> |
| Is the work area separated and marked with appropriate warning boards? | <input type="checkbox"/> | <input type="checkbox"/> | <input type="checkbox"/> |
| Has the work place been protected against sparks? | <input type="checkbox"/> | <input type="checkbox"/> | <input type="checkbox"/> |
| Was the area sprayed with water? | <input type="checkbox"/> | <input type="checkbox"/> | <input type="checkbox"/> |
| Have curtains or covers been made? | <input type="checkbox"/> | <input type="checkbox"/> | <input type="checkbox"/> |
| Have sewage sumps and drains been secured within a radius of 20 m from an open fire work site? | <input type="checkbox"/> | <input type="checkbox"/> | <input type="checkbox"/> |
| Does the welding set have a valid periodic inspection? | <input type="checkbox"/> | <input type="checkbox"/> | <input type="checkbox"/> |

Do the Contractor's employees know:

YES NO

- | | | |
|--|--------------------------|--------------------------|
| How to proceed in the event of a chemical alarm announcement? | <input type="checkbox"/> | <input type="checkbox"/> |
| What to do in the event of a fire? | <input type="checkbox"/> | <input type="checkbox"/> |
| What to do in the event of an accident? | <input type="checkbox"/> | <input type="checkbox"/> |
| What is the Company Emergency Number in Plock? | <input type="checkbox"/> | <input type="checkbox"/> |
| Where are the assembly muster points for evacuation? | <input type="checkbox"/> | <input type="checkbox"/> |
| Where are the weather vanes - in what direction is the wind blowing? | <input type="checkbox"/> | <input type="checkbox"/> |

All employees of the Contractor were trained in the performance of particularly hazardous works on the premises of ORLEN and participated in the thread analysis and know its content.

.....
Contractor's name/surname

.....
Legible signature

IT IS PROHIBITED TO ISSUE A DAILY CARD – ONE-OFF PERMIT, IF ONE OF THE ANSWERS IN THE HAZARD ANALYSIS/ QUESTIONNAIRE IS "NO"!!!!!!

**Annex no. B/2****NAME LIST OF STAFF MEMBERS OF THE EXECUTIVE TEAM**For Daily Card – One-off permit no.

(training was conducted for the after – mentioned staff)

No.	First name and surname	Access card No.	Authorised to receive permits (YES)
1.			
2.			
3.			
3.			
4.			
5.			
6.			
7.			
8.			
9.			
10.			
11.			
12.			
13.			
14.			
15.			
16.			
17.			
18.			
19.			
20.			
21.			
22.			
23.			
24.			

Training for the above-mentioned subordinate employees were carried out by the Contractor – the person collecting the permit.

.....
Date

.....
Contractor legible signature



EXCAVATION CONTROL CARD

I. TYPE OF EXCAVATION:

- | | |
|--|--|
| <input type="checkbox"/> narrow-space (bottom width <1,5 m.) | <input type="checkbox"/> wide space (bottom width > 1,5m.) |
| <input type="checkbox"/> shallow (depth < 1m.) | <input type="checkbox"/> semi-deep (depth >1m. and < 3 m.) |
| <input type="checkbox"/> deep (depth > 3 m.) | |

II. PROTECTION OF THE EXCAVATION WALLS AND THE TERRAIN :

- | | |
|---|--|
| <input type="checkbox"/> grading | <input type="checkbox"/> formwork |
| <input type="checkbox"/> sheet piling | <input type="checkbox"/> palisades |
| <input type="checkbox"/> permanent fencing | <input type="checkbox"/> marking with OHS information boards |
| <input type="checkbox"/> excavation lighting (at dusk and at night) | <input type="checkbox"/> others- |

III. COMMUNICATION IN THE EXCAVATION:

- | | |
|--|---|
| <input type="checkbox"/> stairs up to every 20 m | <input type="checkbox"/> ladders up to every 20 m |
| <input type="checkbox"/> scaffolding | <input type="checkbox"/> other - |

IV. REQUIRED EARTHWORKS DOCUMENTATION:

- | | |
|--|--|
| <input type="checkbox"/> JSA (*obligatorily required in accordance with the Ordinance 13/2022/PB) | <input type="checkbox"/> BIOZ plan |
| <input type="checkbox"/> IBWR (*obligatorily required in accordance with the Ordinance 13/2022/PB) | <input type="checkbox"/> detailed design and a sketch of obstacles |
| <input type="checkbox"/> excavation project (*obligatorily required in accordance with the Ordinance 5/2018/ZB, for excavation with depth > 4m.) | |
| <input type="checkbox"/> other - | |

V. REQUIRED COLLECTIVE AND PERSONAL PROTECTION MEASURES:

- | | |
|---|--|
| <input type="checkbox"/> safety harness with an evacuation rope | <input type="checkbox"/> Belayer |
| <input type="checkbox"/> safety cage | <input type="checkbox"/> elevator for goods and passengers |
| <input type="checkbox"/> other - | |

VI. Excavation Acceptance Report:

The name of the excavation user(s):		
Date of the inspection (max. every 10 days):	Date:	Signature:
Phone number of the excavation contractor		

.....
 Date and signature of the Site Manager – Contractor admitting the excavation for exploitation

Annex no. 41*Checklist for scaffolding inspection*

No.	Place of inspection:	The scaffolding company:		
	Scaffolding acceptance protocol number:			
	INSPECTION CRITERIA	YES	NO	NOT APPLICABLE
1	Has the scaffolding acceptance been confirmed in the technical acceptance protocol?			
2	Is the scaffolding sufficiently marked, (i.e. name and surname of the Installer, contact telephone number, permissible load on the platforms/structures, order to use of PPE)?			
3	Is there an assembly manual / DTR / individual design for the scaffolding and is it available for inspection at the assembly site ?			
4	Are there any pads for the scaffolding bolt shoes?			
5	Do the employees apply the required and operational PPE?			
6	Is the scaffolding anchored in accordance with with the manufacturer's instructions, DTR or an individual project?			
7	Is the scaffolding properly grounded?			
8	Is the place of work at heights carried out from the scaffolding permanently fenced and marked with information boards?			
9	Do the landing (overhead) boards supported on crossbars have the correct length of the overlap on each side of the base?			
10	Do work platforms have complete railings (toe boards, intermediate and top handrail)?			
11	Are the scaffolding communication lines kept and if their number is correct?			
12	Are the access covers closed after each passage?			
13	Are the boards / logs the correct thickness according to the scaffolding documentation?			
14	Are the platforms tightly arranged, i.e. secured against rising and shifting?			
15	Is the permissible load of the platforms / scaffolding not exceeded?			
16	Are the vertical and horizontal braces provided for in the scaffolding documentation applied?			
17	Is there a distance of 0.2 m between the object under construction and the scaffolding platform (if NO, see point below)?			

Appendix no. 4 to the General Safety Requirements – Guidelines No. 2

18	Are consoles, interior rails or safety harness used when a distance of 0.2 m is exceeded?			
19	Are the scaffolding platforms free of excess debris, materials, obstructions as well as ice / snow?			
20	Are the changes to the scaffolding arrangement made by the company assembling the scaffolding?			
21	Are the materials, tools etc. left on the scaffolding after completion of works?			
22	Are the scaffolding inspections carried out in accordance with the scaffolding documentation?			
23	Does the company using the scaffolding make entries in the "Extract from the acceptance report"?			
24	Does the faulty / incomplete scaffolding have a sign saying that access to the scaffolding is prohibited?			

REMARKS:

INSPECTOR: (name, surname, date, stamp/signature):

